

CITIZEN

User's Manual

Model : iDP-3550/3551

Dot Matrix Printer

Rev 1.00 Newly Issued on 01.Mar.1999

Japan CBM Corporation
Information Systems Div.

Declaration of Conformity

Manufacturer's Name : Japan CBM Corporation
Manufacturer's Address : CBM Bldg., 5-68-10, Nakano, Nakano-ku
Tokyo, 164-0001, Japan

Declare the Product

Product Name Dot Matrix Printer
Model Number(s) iDP-3550 Series
(iDP-3550RF/PF, iDP-3550SF/CF, iDP-3550TF/IF)
(S.No.9930001 -)

Conform to the following Standards

EMC : EN55022 : 1994+A1:1995+A2:1997 Class A
: EN61000-3-2 : 1995
: EN61000-3-3 : 1995
: EN50082-1 : 1997
: EN61000-4-2 : 1995 ±4KV CD, ±8KV AD
: EN61000-4-3 : 1996 3V/m, 80MHz-1000MHz AM 1KHz 80%
: ENV50204 : 1995 3V/m, 895MHz-905MHz
(Pulse 200Hz, duty cycle 50%)
: EN61000-4-4 : 1995±1.0KV(AC Mains),±0.5KV(Signal Lines)
: EN61000-4-5 : 1995 1KV Normal mode, 2KV Common mode
: EN61000-4-6 : 1996 3V, 0.15MHz-80MHz AM 1KHz 80%
: EN61000-4-8 : 1993 50Hz, 3A/m
: EN61000-4-11 : 1994 0%, 500ms/40%, 100ms/70%, 10ms

Supplementary Information

“The product complies with the requirements of the Low Voltage Directive 73/23/EEC, 93/68/EEC and the EMC Directive 89/336EEC, 92/31/EEC, 93/68EEC”

Place Tokyo, Japan

Signature



Date February.1999

Full Name : Mikio Moriya

Position : General Manager

R & D Department

European Contact :

Norco Declaration AB

Box 7146 S-250 07 Helsingborg Sweden

Warning : This is a Class A products. In a domestic environment this product may cause radio interference in which case the user may be required to take adequate measures.

This declaration is applied only for 230V model.

IMPORTANT SAFETY INSTRUCTIONS

- Read all of these instructions and save them for future reference.
- Follow all warnings and instructions marked on the product.
- Unplug this product from the wall outlet before cleaning. Do not use liquid or aerosol cleaners. Use a damp cloth for cleaning.
- Do not use this product near water.
- Do not place this product on an unstable cart, stand or table. The product may fall, causing serious damage to the product.
- Slots and openings on the back or bottom of the case are provided for ventilation. To ensure reliable operation of the product and to protect it from overheating, do not block or cover these openings. The openings should never be blocked by placing the product on a bed, sofa, rug or other similar surface. This product should never be placed near or over a radiator or heater. This product should not be placed in an built-in installation unless proper ventilation is provided.
- This product should be operated from the type of power source indicated on the marking label. If you are not sure of the type of power available, consult your dealer or local power company.
- Do not allow anything to rest on the power cord. Do not place this product where the cord will be walked on.
- If an extension cord is used with this product, make sure that the total of the ampere ratings of the products plugged into the extension cord does not exceed the extension cord ampere rating. Also, make sure that the total of all products plugged into the wall outlet does not exceed 15 amperes.
- Never push objects of any kind into this product through cabinet slots as they may touch dangerous voltage points or short out parts that could result in a risk of fire or electric shock. Never spill liquid of any kind on the product.
- Except as explained elsewhere in this manual, do not attempt to service this product by yourself. Opening and removing the covers that are marked "Do Not Remove" may expose you to dangerous voltage points or other risks. Refer all servicing on those compartments to service personnel.
- Unplug this product from the wall outlet and refer servicing to qualified service personnel under the following conditions:
 - A. When the power cord or plug is damaged or frayed.
 - B. If liquid has been spilled into the product.
 - C. If the product has been exposed to rain or water.
 - D. If the product does not operate normally when the operating instructions are followed. Adjust only those controls that are covered by the operating instructions since improper adjustment of other controls may result in damage and will often require extensive work by a qualified technician to restore the product to normal operation.
 - E. If the product has been dropped or the cabinet has been damaged.
 - F. If the product exhibits a distinct change in performance, indicating a need for service.
- Please keep the poly bag which this equipment is packed in away from children or throw it away to prevent children from putting it on. Putting it on may cause suffocation.

WICHTIGE SICHERHEITSANWEISUNGEN

- Lesen Sie die nachfolgenden Anweisungen sorgfältig durch und bewahren Sie sie auf.
- Befolgen Sie alle auf dem Drucker vermerkten Hinweise und Anweisungen. Vor dem Reinigen

grundsätzlich Stecker aus der Steckdose ziehen. Keine Flüssigkeiten oder Aerosolreiniger benutzen. Nut mit einem feuchten Tuch abwischen.

- Der Drucker darf nicht in der Nähe von Wasser aufgestellt werden.
- Drucker nicht auf einem unstabilen Wagen, Stand oder Tisch aufstellen. Der Drucker könnte herunterfallen und dabei beschädigt werden.
- Schlitze und Öffnungen im Gehäuse, in der Rückwand und im Boden dienen der Belüftung. Sie dürfen keinesfalls zugedeckt oder blockiert werden, da sich der Drucker sonst überhitzt. Drucker nicht auf ein Bett, Sofa, Teppich oder dergleichen stellen. Drucker nicht in der Nähe eines Heizkörpers aufstellen. Drucker darf nicht eingebaut werden, falls nicht für ausreichende Belüftung gesorgt ist.
- Drucker nur mit der auf dem Typschild angegebenen Spannung betreiben. Wenn Sie sich nicht sicher sind, fragen Sie ihren Händler oder ihr zuständiges Elektrizitätswerk.
- Nichts auf das Stromanschlußkabel stellen. Kabel muß so verlegt werden, daß man nicht darauftreten kann.
- Ein etwaiges Verlängerungskabel muß der Stromstärke aller daran angeschlossenen Geräte entsprechen.
- Keine Gegenstände in die Gehäuseschlitze schieben.
- Drucker darf nur da gewartet werden, wo im Handbuch angegeben, Öffnen und. Abnehmen von Abdeckungen, die mit "Do not remove" gekennzeichnet sind, könnte gefährliche spannungsführende Stellen oder sonstige Gefahrenpunkte freilegen. Die Wartung solcher Stellen darf grundsätzlich nur von besonders ausgebildetem Fachpersonal vorgenommen werden.
 - A. Wenn das Stromanschlußkabel oder der Stecker beschädigt oder durch-gescheuert ist.
 - B. Wenn Flüssigkeit auf dem Drucker verschüttet wurde.
 - C. Wenn der Drucker im Regen gestanden hat oder Wasser darauf verschüttet wurde.
 - D. Wenn der Drucker trotz genauer Befolgung der Betriebsvorschriften nicht richtig arbeitet. Nur die in der Bedienungsanleitung angegebenen Einstellungen vornehmen. Ein Verstellen anderer Bedienelemente könnte den Drucker beschädigen und macht umständliche Arbeiten eines qualifizierten Technikers erforderlich, um den Drucker wieder auf den normalen Betrieb einzustellen.
 - E. Wenn der Drucker heruntergefallen ist oder das Gehäuse beschädigt wurde.
 - F. Wenn der Drucker in seiner Leistung nachläßt.
- Bitte halten Sie den Kunststoffbeutel, in den die Ware verpackt ist, von Kindern entfernt, oder werfen Sie ihn weg, damit er nicht in die Hände von Kindern gerät. Das Überstülpen des Beutels kann zum Ersticken führen.

Lärmemission kleiner 70dBA

IMPORTANT: This equipment generates, uses, and can radiate radio frequency energy and if not installed and used in accordance with the instruction manual, may cause interference to radio communications. It has been tested and found to comply with the limits for a Class A computing device pursuant to Subpart J of Part 15 off FCC Rules, which are designed to provide reasonable protection against such interference when operated in a commercial environment. Operation of this equipment in a residential area is likely to cause interference, in which case the user at his own expense will be required to take whatever measures may be necessary to correct the interference.

CAUTION: Use shielded cable for this equipment.

Sicherheitshinweis

Die Steckdose zum Anschluß dieses Druckers muß nahe dem Grät angebracht und leicht zugänglich sein.

For Uses in Canada

This digital apparatus does not exceed the class A limits for radio noise emissions from digital apparatus, as set out in the radio interference regulations of the Canadian department of communications.

Pour L'utilisateurs Canadiens

Cet appareil numérique ne dépasse pas les limites de carégorie a pour les émissions de bruit radio émanant d'appareils numériques, tel que prévu dans les réglemets sur l'interférence radio du département Canadien des communications.





<CAUTIONS>

1. Prior to using the equipment, be sure to read this User's Manual thoroughly. Please keep it handy for reference whenever it may be needed.
2. The information contained herein may be changed without prior notice.
3. Reproduction of part or all of this User's Manual without permission is strictly prohibited.
4. Never service, disassemble, or repair parts that are not mentioned in this User's Manual.
5. Note that we will not be responsible for damages attributable to a user's incorrect operation/ handling or an improper operating environment.
6. Operate the equipment only as described in this User's Manual; otherwise accidents or problems may result.
7. Data are basically temporary; they cannot be stored or saved permanently or for a long time. Please note that we will not be responsible for damages or losses of profit resulting from losses of the data attributable to accidents, repairs, tests, and so on.
8. If you have any questions or notice any clerical errors or omissions regarding the information in this manual, please contact our office.
9. Please note that, notwithstanding Item 8 above, we will not be responsible for any effects resulting from operation of the equipment.

SAFETY PRECAUTIONS ----- BE SURE TO OBSERVE

In order to prevent hazards to an operator or other persons and damage to property, be sure to observe the following precautions.

- The following describes the degrees of hazard and damages that can occur if the given instructions are neglected or the equipment is incorrectly operated.

	WARNING	Negligence of this precaution may result in death or serious injury.
	CAUTION	Negligence of this precaution may result in injury or damage to property.
		This is an illustration mark used to alert your attention.
		This is an illustration mark used to indicate such information as an instruction or the like.



WARNING

- Never handle the equipment in the following manners, as it may break, become out of order, or overheat causing smoke and resulting in fire or electric shock.
If the equipment is used in an abnormal condition, such as when broken, then problems, smoke emission, abnormal odor/noise, and fire can result. If an abnormal condition exists, be sure to turn off the power, disconnect the power plug from a plug socket, and contact our dealer. Never repair the equipment on your own - it is very dangerous.
- Do not allow the equipment to receive a strong impact or shock, such as kicking, stomping, hitting, dropping, and the like.
- Install the equipment in a well-ventilated place. Do not use it in such a manner that its ventilation port will be blocked.
- Do not install the equipment in a place like a laboratory where chemical reactions are expected, or in a place where salt or gases are contained in the air.
- Do not connect/disconnect a power cord or a data cable, while holding the cable. Do not pull, install, use, or carry the equipment in such a manner that force will be applied to the cables.
- Do not drop or insert any foreign substances, such as clips or pins, into the equipment.
- Do not spill any liquid or spray any chemical-containing liquid over the equipment. If any liquid is spilled on it, turn off the power, disconnect the power cable and power cord from the plug socket, and so on, and contact our dealer.
- Do not disassemble or remodel the equipment. Negligence of this may cause fire or electric shock.
- Should water enter inside the equipment by any chance, unplug it and contact our office. Using it in that condition may result in fire or electric shock.
- Use the equipment only with the specified commercial power supply. Negligence of this may result in fire, electric shock, or problems.
- Do not damage, break, alter, excessively twist, pull, or bundle the power cord. Avoid placing heavy objects on, or heating the power cord, as this may lead to damages to the power supply which may cause a fire, an electric shock, or a malfunction. Contact our office if the power cord is damaged.
- Do not connect/disconnect the power cord with wet hands. It may result in an electric shock or other problems.
- Do not overload a single electrical outlet, using a table tap or a current tap socket. It may result in fire or electric shock.
- An equipment packing bag must be discarded or kept away from children. A child can suffocate if the bag is placed over the head.



PRECAUTIONS FOR INSTALLATION

- Do not use or store the equipment in a place exposed to fire, moisture, or direct sunlight, or in a place near a heater or a thermal device where the prescribed operating temperature and humidity are not met, or in a place exposed to much oil, iron powder, or dust. The equipment may become out of order, emit smoke, or catch fire.
- Do not install the equipment in a place like a laboratory where chemical reactions are expected, or in a place where salt or gases are contained in the air. There is a danger of fire or electric shock.
- Do not put any object on the printer. It may cause trouble.
- Do not use the equipment near a radio or TV receiver. Do not share the power from a plug socket a radio or TV receiver is connected to. It may cause a reception problem.
- Use the equipment only at the specified voltage and frequency. Otherwise, it may emit smoke and catch fire or cause other problems.
- Confirm that a plug socket used for connection has sufficient capacity.
- Do not overload a single electrical outlet in connecting the power cable. It may result in the cable catching fire or a power outage. Also, do not stamp or put any object on the cable.
- Never connect a grounding cable to a gas pipe. There is a danger of explosion. When connecting or disconnecting the grounding cable, be sure to disconnect the power plug from the plug socket.
- When connecting/disconnecting the cables, be sure to turn off the power first, including the connected side, and then connect/disconnect them, holding a plug and a connector. Do not pull or carry the equipment with a load applied to the cable.
- Connect a connector cable securely. If a reverse-polarity connection is made, internal elements may be broken or a mating device may be adversely affected.
- Use a shielding wire or twisted pair wire for a signal line, in order to minimize noise effect. Avoid connecting to a device that is likely to generate noise.
- When a drawer kick connector is provided, do not connect any device other than the prescribed solenoid specifications. Negligence of this could cause trouble.
- Use the equipment in an environment where there is a plug socket near the main body and you can easily disconnect the power plug from it, to shut off the power.
- When the equipment will not be used for a long period of time, unplug it.
- When transporting the equipment, remove the rolled paper from it.
- Install the equipment on a flat, stable desk in a well-ventilated place free from vibrations. (Do not block the ventilation port.)



PRECAUTIONS FOR HANDLING

Do not handle the equipment in the following manners, because problems may result.

- Do not print when there is no recording paper or ink ribbon set in the equipment. The print head may be damaged
- Be careful not to drop foreign substances, such as clips, pins, and screws, into the main body.
- Do not spill any liquid or spray any chemical-containing liquid over the equipment.
- Do not stamp on, drop, hit, or give a strong shock to the equipment.
- Never use a pointed object, such as a pen, to operate the operation panel.
- Do not use Scotch tape to fasten paper together for continuous use.
- Never pull the set paper forcibly. When opening/closing the printer cover, take care that the paper will not be caught.

To Prevent Injury and Spreading of Damage

- Do not touch the printing part of the print head.
- When turning on the power, do not touch the moving parts, such as a cutter and gear inside the main body, or electric parts.
- Be careful to avoid bodily injure or damaging other objects with an edge of sheet metal.
- Should any error occur while operating the equipment, stop it immediately and disconnect the power plug from the plug socket.
- Should a problem occur, leave solving it to our serviceman. Do not disassemble the equipment on your own.
- When opening/closing the cover, and so on, be careful not to catch your hand or finger on the equipment.

① DAILY MAINTENANCE

- Prior to starting maintenance work, be sure to turn off the main body.
- Use a dry soft cloth to wipe off stains and dust from the surfaces of the main body case. For severe soiling, dip the cloth in water and wring it, for wiping off the soil. Never use organic solvents, such as alcohol, thinner, trichlene, benzene, ketone, or chemical dusters.
- If the equipment is contaminated with paper powder, use a soft brush to clean it.

CONTENTS

1. OUTLINE.....	1
1.1 Features.....	1
1.2 Unpacking.....	1
2. BASIC SPECIFICATIONS	2
2.1 Model Classifications	2
2.2 Basic Specifications.....	3
2.3 Paper Specifications	4
2.3.1 Recommended Paper.....	4
2.3.2 Printing Position.....	4
2.3.3 Cutter Layout	4
3. OUTER APPEARANCE AND COMPONENT PARTS.....	5
3.1 iDP-3550.....	5
3.2 iDP-3551.....	6
4. OPERATION	8
4.1 Detaching/Attaching the Printer Cover	8
4.2 Connecting the Interface Cable	8
4.3 Connecting the Drawer Kick-Out Connector	9
4.4 Opening/Closing the Auto Cutter (iDP-3551).....	9
4.5 Setting the Ribbon Cassette.....	10
4.6 Inserting the Paper.....	11
4.7 Attaching the Rear Cover	13
4.8 How to Remove Remaining Paper Roll	13
4.9 Removing Paper Jam	13
4.10 Unlocking the Cutter (iDP-3551)	14
4.11 Operation Panel and Display of Error	15
5. DIP SWITCH SETTING	17
5.1 Location of DIP Switch.....	17
5.2 DIP Switches Setting.....	18
6. PRESET JUMPER SETTING.....	20
6.1 Location of Preset Jumper	20
6.2 Preset Jumper Table	20
7. MODE SETTING METHOD	21
8. INPUT BUFFER BACKUP FUNCTION	22
8.1 Buffer Size.....	22
8.2 Input Buffer Backup	22
8.3 Clearing the Input Buffer.....	22
9. PARALLEL INTERFACE	23
9.1 Specifications	23
9.2 Connector's Pin Configuration	23
9.3 Input and Output Signals	24
9.3.1 Input and Output Signals.....	24
9.3.2 Electrical Characteristics.....	25
9.3.3 Timing Chart	26

9.3.4	Data Receiving Control.....	26
10.	SERIAL INTERFACE.....	27
10.1	Specifications	27
10.2	Connector's Pin Configuration	28
10.3	Input and Output Signals	29
10.3.1	Input and Output Signals.....	29
10.3.2	Data Configuration.....	31
10.3.3	Error Detection.....	32
10.3.4	Data Receiving Control.....	32
10.3.5	Buffering	32
10.3.6	Electrical Characteristics.....	32
11.	DRAWER KICK-OUT CONNECTOR	34
11.1	Specifications of Drawer Kick-Out Connector	34
11.2	Connector's Pin Configuration	34
11.3	Drive Circuit.....	34
12.	WINDER CONNECTOR.....	35
12.1	Specifications of Winder Connector.....	35
12.2	Connector's Pin Configuration	35
12.3	Drive Circuit.....	35
13.	MAINTENANCE AND SERVICE	36
14.	PRINT CONTROL FUNCTIONS	37
14.1	CBM Mode.....	37
14.1.1	Command List.....	37
14.1.2	Description of Items	39
14.2	STAR Mode.....	57
14.2.1	Command List.....	57
14.3	ESC/POS Commands	86
14.3.1	Command List.....	86
15.	CHARACTER CODES TABLE.....	108
15.1	CBM (Domestic)	108
15.2	CBM (International)	109
15.3	STAR (Domestic).....	110
15.4	STAR (International).....	111
15.5	Code Page 437	112
15.6	Katakana	113
15.7	Code Page 850.....	114
15.8	Code Page 860.....	115
15.9	Code Page 863.....	116
15.10	Code Page 865.....	117
15.11	Code Page 852.....	118
15.12	Code Page 866.....	119
15.13	Code Page 857.....	120
15.14	Windows Code	121
15.15	International Character Codes Table	122
APPENDIX 1.	BLOCK DIAGRAM	123
APPENDIX 2.	OUTLINE DRAWING for iDP-3550	124

APPENDIX 3. OUTLINE DRAWING for iDP-3551 125

<<< German >>>

4. BETRIEB.....	133
4.1 Druckerabdeckung Aufsetzen, Entfernen.....	133
4.2 Anschluß des Schnittstellenkabels	134
4.3 Anschluß des Schubladenausschubsteckers	135
4.4 Öffnen/Schließen des automatischen Schneidemechanismus (iDP-3551).....	135
4.5 Einlegen der Farbbandkassette	135
4.6 Einlegen des Papiers.....	136
4.7 Hintere Abdeckung des Druckers aufsetzen.....	138
4.8 Herausnehmen der Restpapierrolle.....	138
4.9 Beseitigung von Papierstaus.....	139
4.10 Initialisierung des Schneidemechanismus.....	139
4.11 Bedienfeld und Fehleranzeigen	139
5. DIP-SCHALTER-EINSTELLUNG	142
5.1 Lage der DIP-Schalter	142
5.2 DIP-Schalter-Einstellungen.....	143
6. EINSTELLUNG DER VORWAHL-JUMPERSTECKER.....	145
6.1 Lage der Vorwahl-Jumperstecker.....	145
6.2 Vorwahl-Jumperstecker-Tabelle.....	145
7. METHODE FÜR MODUSEINSTELLUNG.....	145
12. WARTUNG UND DIENST.....	146

Note:

Citizen, Citizen logo are registered trademark of Citizen Watch Co., Ltd.

ESC/POS and EPSON are a trademark and registered trademark of SEIKO EPSON Corporation.

STAR is a registered trademark of Star Micronics Corporation.

Windows is a registered trademark of Microsoft Corporation.

1. OUTLINE

This is a small-size dot impact printer developed for various data communication terminals, POS terminals, kitchen-use printers, and so on.

Its abundant built-in features allow you to widely use this printer for different applications. Prior to using it, read and understand this manual thoroughly.

1.1 Features

- (1) Small size, light weight, and low price
- (2) High-speed print (Bi-directional)
- (3) Red and black print
- (4) Very easy paper loading by the auto loading function
- (5) Paper end and paper near end detecting function
- (6) Built-in auto cutter (ACS-130) (iDP-3551)
- (7) Built-in power supply

1.2 Unpacking

- (1) When unpacking the printer, confirm that the following parts are provided.

•Printer body	----- 1 unit
•Cassette ribbon	----- 1 piece
•Sample paper roll	----- 1 roll
•User's manual	----- 1 copy



CAUTION :

- Install the printer on a flat and stable desk.
- Do not install the printer near a heater or in a place exposed to direct sunlight.
- Do not use the printer in a high-temperature, high-humidity, and contaminated environment.
- Do not allow dew condensation on the printer. If dew is condensed on it, leave the power turned off until dew condensation is gone.

2. BASIC SPECIFICATIONS

2.1 Model Classifications

The printer model is classified by the following designation method.

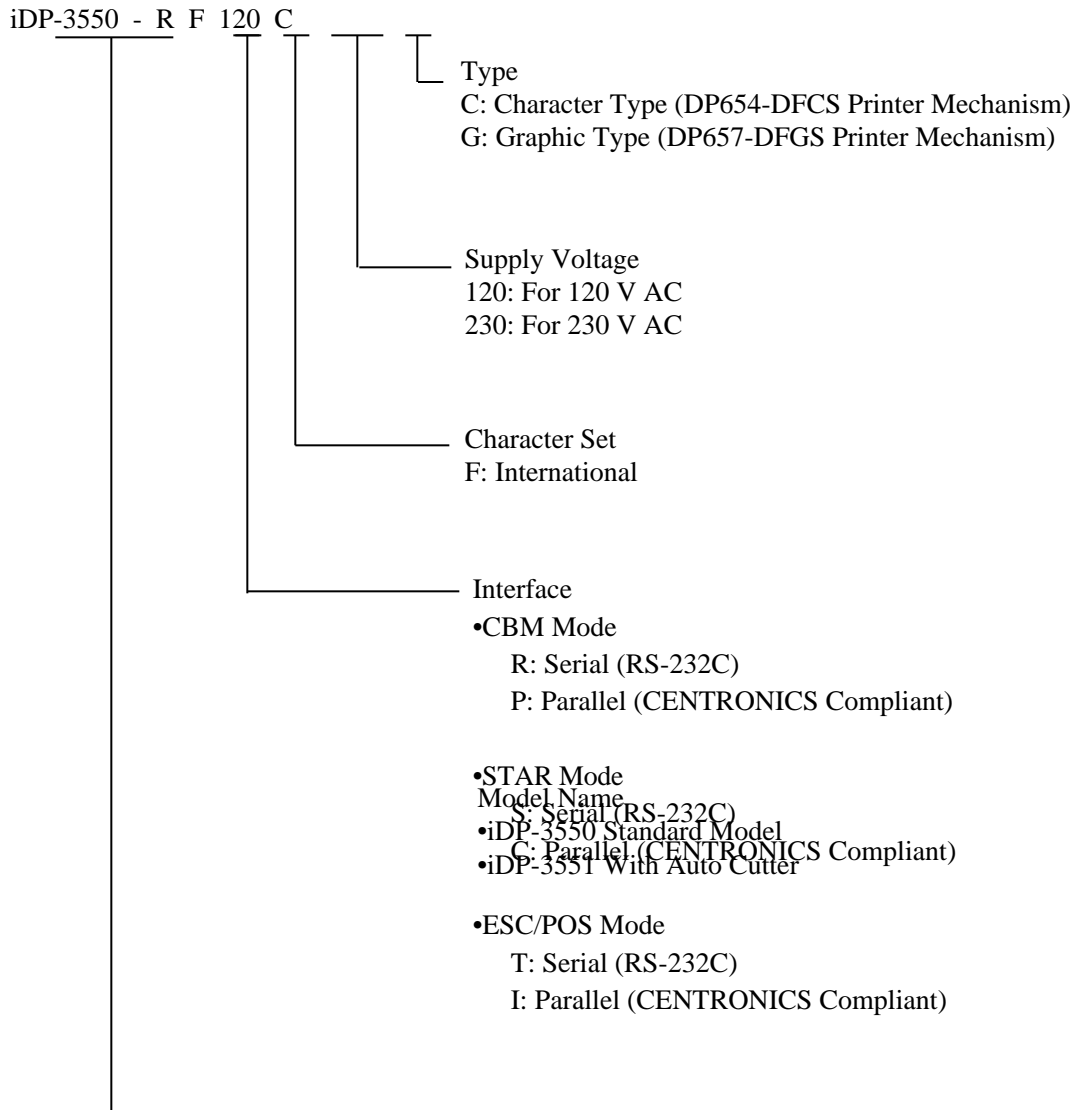

2.2 Basic Specifications

Item \ Model	iDP-3550	iDP-3551
Printer mechanism	Character type: DP654 series/Graphic type: DP657series (CITIZEN)	
Print method	Serial dot impact method (Bidirectional print), 2-pass graphic (Unidirectional print)	
Print width	Character type: 63.6 mm/Graphic type: 58.7 mm	
Print head	9 pins	
Print speed	Character type: Approx. 3.6 lines/second/Graphic type: Approx. 3 lines/second	
Print columns	40 columns	
Character size	Character type: 1.36 mm(W) × 2.4 mm(H) (7 dots) 1.36 mm(W) × 3.1 mm(H) (9 dots) Graphic type: 1.36 mm(W) × 2.4 mm(H) (7 dots) 1.36 mm(W) × 3.1 mm(H) (9 dots)	
Character types	Alphanumeric, Katakana, International characters, Code page 850, 860, 863, 865, 852, 866, 857, Windows code	
Line spacing	Character type: 4.23 mm (1/6 inch)/Graphic type: 2.82mm (1/9 inch)	
Paper	Ordinary paper and non-carbon paper: 76 +/- 0.5 mm(W) × 83 mm(OD);	
Ink ribbon	Special purpose ribbon cartridge red/black or single color (Black or Purple)	
Interface	Serial(RS-232C), Parallel(CENTRONICS compliant)	
Command system	CBM mode, STAR mode, ESC/POS mode The user can select the mode with the DIP switch and preset jumpers.	
Print function	On-line, self-test, and hex. dump print function Provided by operating the power, LF, and SEL switches.	
Input buffer	6 KB or 256 bytes (Selectable with the DIP switch)	
Buffer backup function	Within 24 hours (After 10 minutes or more of printer operation)	
Drawer function	2-drawer, 1-drawer switch	
Auto loading function	Automatically feeds the paper by several lines when it is inserted.	
Paper end detection	Stops printing when the paper has run out.	
Paper near end detection	Stops printing when the paper is running out.(Settable with a command)	
Auto cutter	None	AC-134-E (Capable of partial and full cut)
Winder	Special purpose winder AW-3-E (Option) that will be placed separately.	
Supply voltage	120 V AC +/- 10 %, 50/60 Hz 230 V AC +/- 10 %, 50/60 Hz	
Power consumption	Not printing: Approx. 10 W, Printing: Approx. 30 W	
Weight	Approx. 2.8 kg	Approx. 3 kg
Outer dimensions	160 (W) × 212 (D) × 194 (H) mm	160 (W) × 212 (D) × 173 (H) mm
Operating temperature and humidity	0 to 40°C, 35 to 85 % RH (No dew condensation)	
Storage temperature and humidity	-20 to 60 °C, 10 to 90 % RH (No dew condensation)	
EMI standard	U.S.A.: FCC Class-A Europe: EN55022 Class-B CE Marking	
Safety standard	U.S.A., Canada: UL, c-UL Europe: TUV, GS	

2.3 Paper Specifications

2.3.1 Recommended Paper

- Type : Normal paper and non-carbon paper
- Paper width : 76 +/- 0.5 mm
- Paper thickness : Single-sheet paper --- 45 to 55 kg/1,000 sheets/1,091 × 788 mm
Copying paper --- Non-carbon paper or 1 original + 1 copy
34 kg for each paper
Total thickness 0.2 mm or less
- Roll diameter : 83 mm or less (80 mm or less for the copying paper)
- Core : 12 mm (Inner Diameter), 18 mm (Outer Diameter)

2.3.2 Printing Position

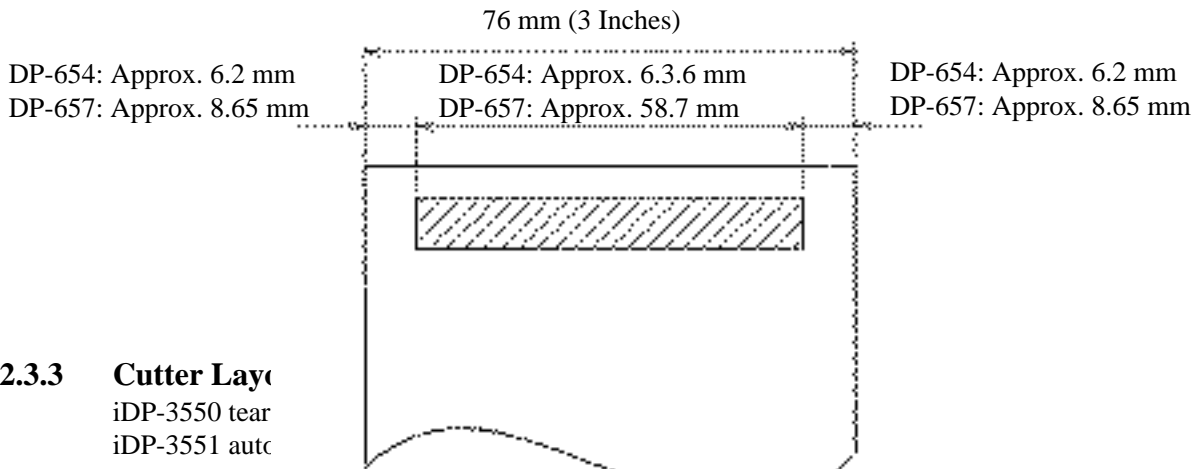

2.3.3 Cutter Layo

- iDP-3550 tear
- iDP-3551 autc

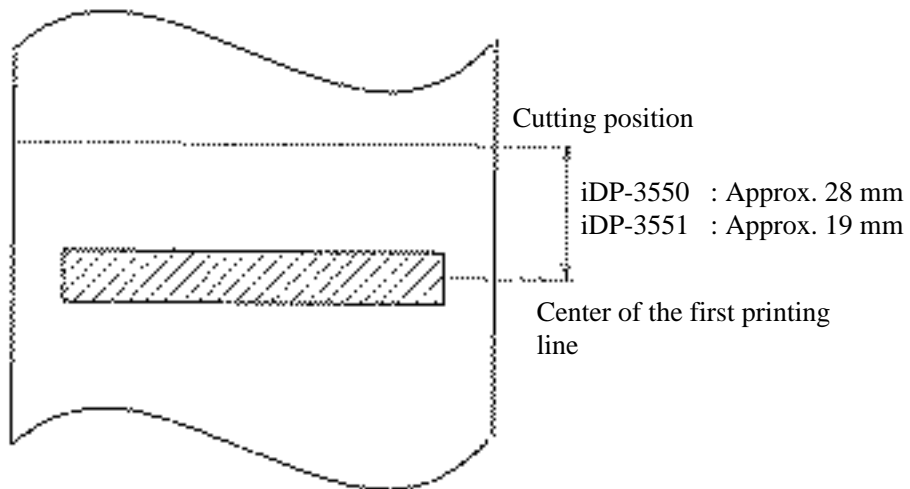

3. OUTER APPEARANCE AND COMPONENT PARTS

3.1 iDP-3550

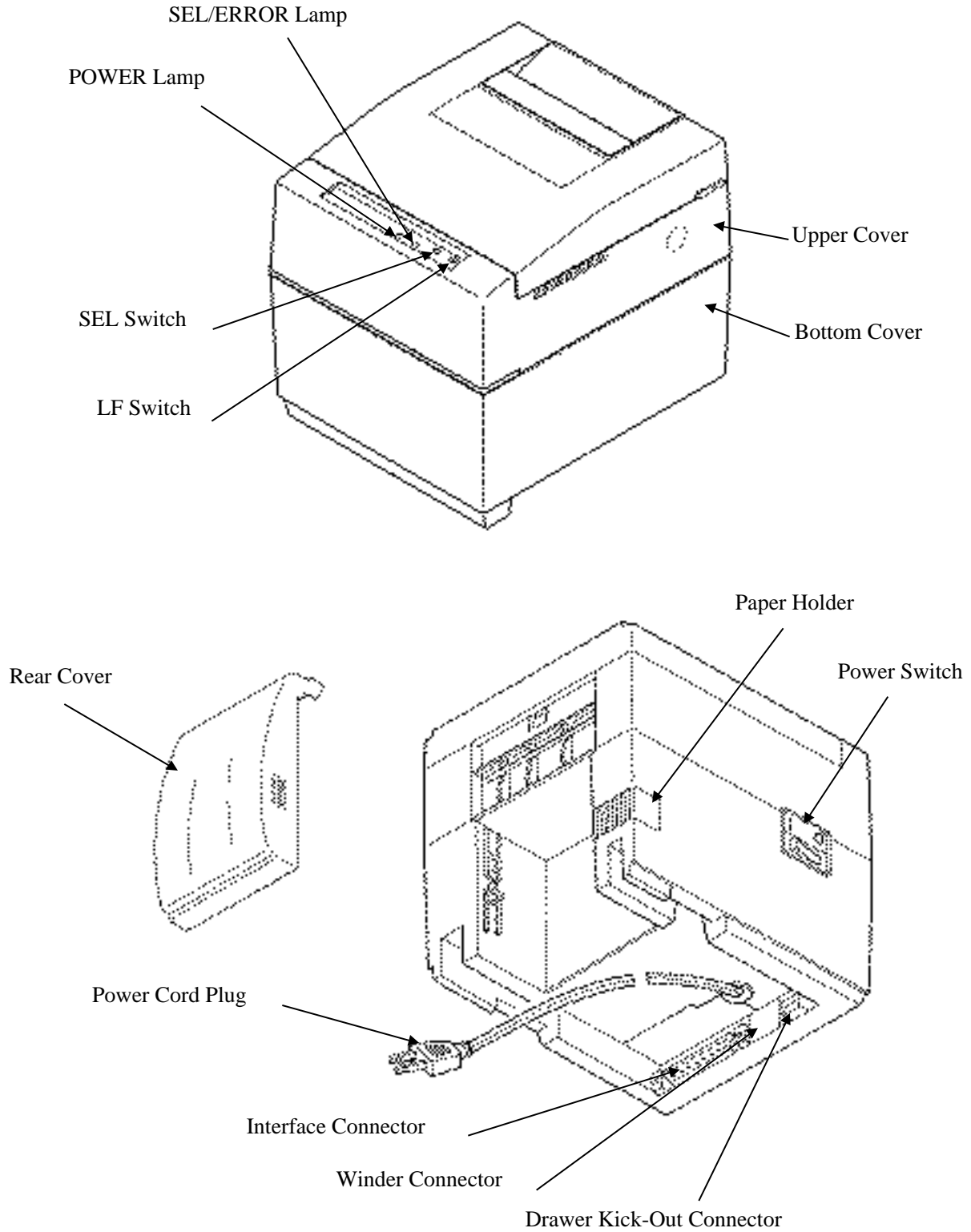

3.2 iDP-3551

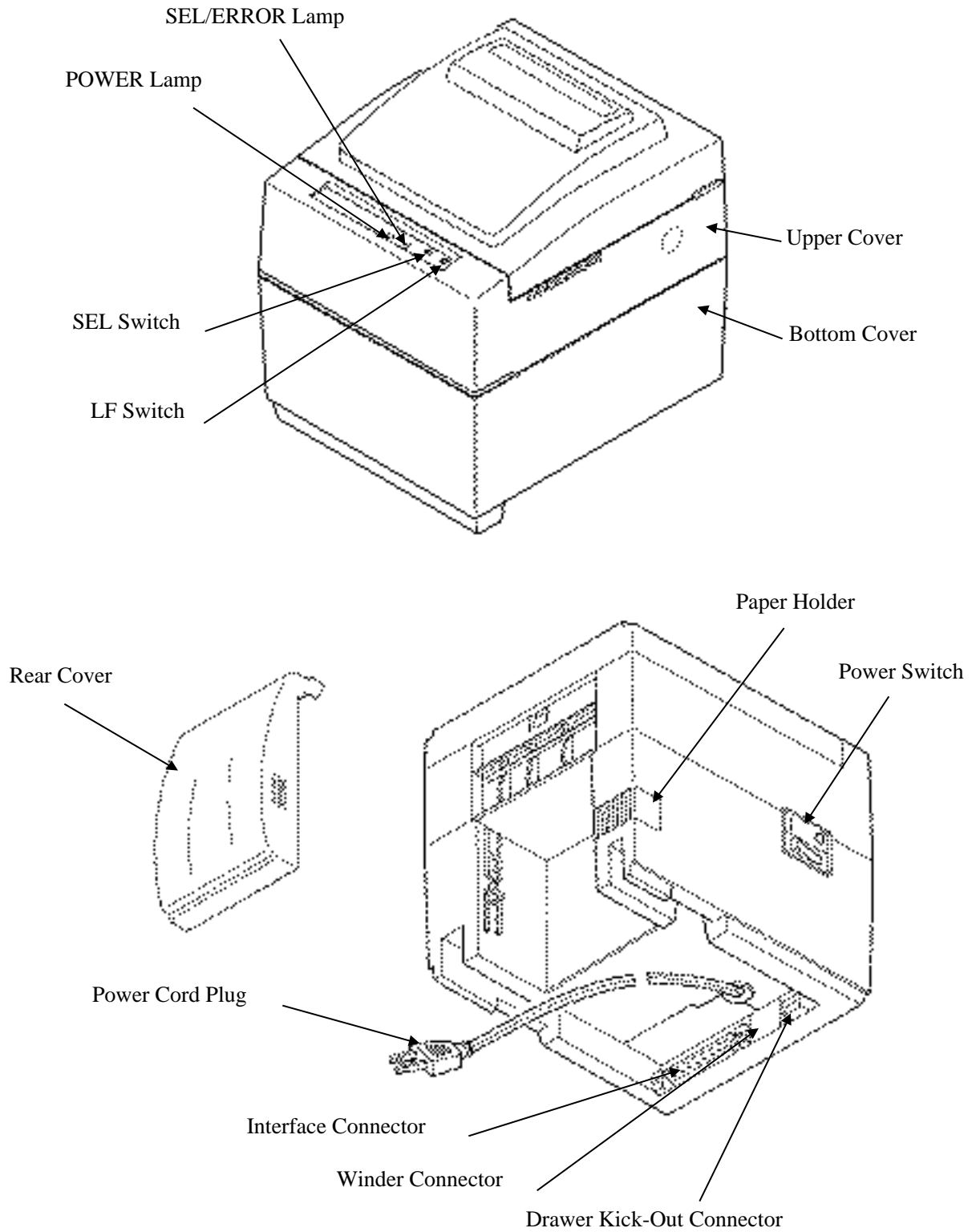

- (1) Power cord plug
Insert it into an AC outlet of the rated voltage.
- (2) Power switch
When the power switch is turned on, the electric power is supplied to the printer and the initializing operation is started..
- (3) POWER lamp (Green LED)
Lights when the power switch is turned on and goes out when it is turned off.
- (4) SEL/ERROR lamp(Green LED)
On: Online
Off: Offline
Flashing (approx. once every second): Out of paper
Flashing (approx. twice every second): Mechanical error (Buzzer sounds once.)
- (5) LF switch
Feeds the paper.
- (6) SEL switch
Changes between select and deselect status. Also used to cancel the alarm status. (In ESC/POS mode, only used to cancel the alarm.)
- (7) Interface connector
Uses a cables to connect to a personal computer. Check that the computer and printer are turned off when connecting.
- (8) External output connector
Drawer control connector.
- (9) Printer cover
Detach when changing the ribbon cassette.
- (10) Rear cover
Paper roll dust cover.
- (11) Winder connector
For an optional winder (AW-3).

4. OPERATION

4.1 Detaching/Attaching the Printer Cover

1. Use both hands to hold the projections on each side of the printer cover and lift the printer cover in the direction shown by the arrow to detach it.
2. When attaching the printer cover, place the hooked part at the front in the appropriate part of the printer and lower the printer cover.

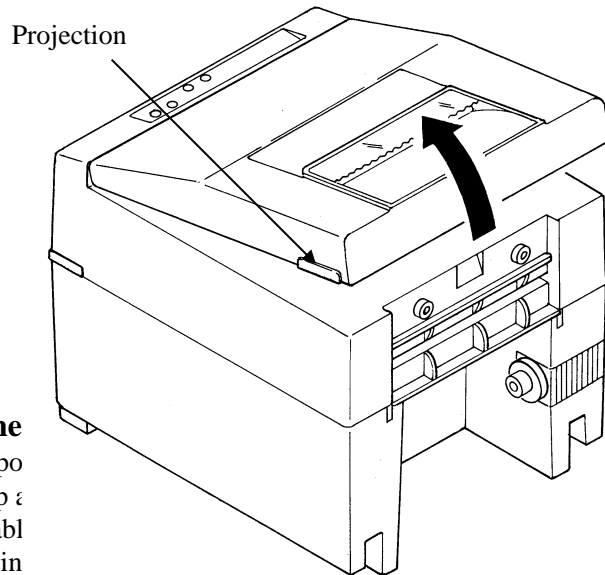

4.2 Connecting the

1. Turn off the power.
2. Check the top of the printer for the Serial or Parallel interface connector.
3. Secure the cable to the printer interface connector. For the Serial interface connector, turn the clamp to secure.
4. Connect the interface cable to the computer.

interface connector.

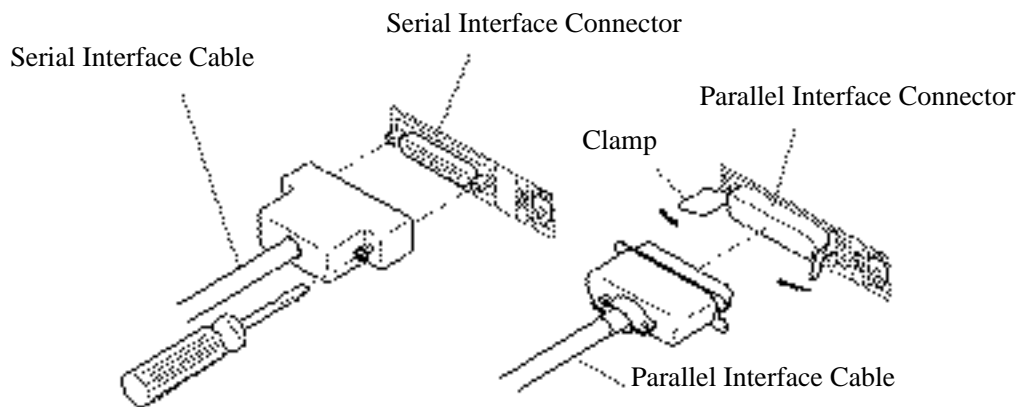

4.3 Connecting the Drawer Kick-Out Connector

1. Turn off the power.
2. Check the top and bottom of the drawer kick-out cable connector and connect it to the drawer kick-out connector located at the lower section of the printer.
3. Screw the grounding cable of the drawer to the grounding terminal located at the lower section of the printer.

 **CAUTION:** •Connect only the prescribed drawer (Solenoid) to the drawer kick-out connector.

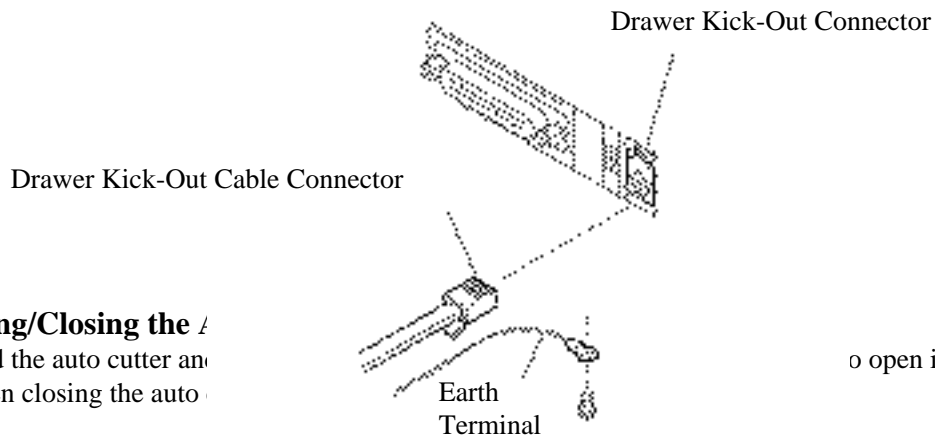

4.4 Opening/Closing the Auto Cutter

1. Hold the auto cutter and
2. When closing the auto

to open it.

 **CAUTION:** •When closing the auto cutter, do so gently not to give a shock.

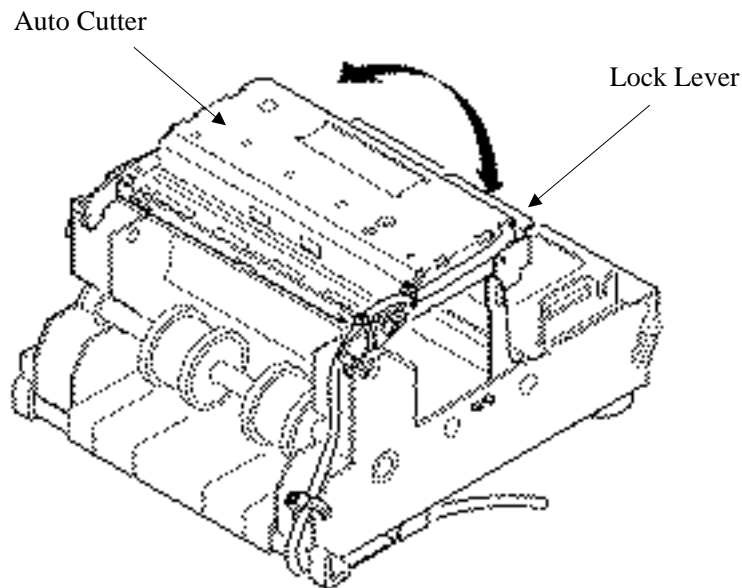

4.5 Setting the Ribbon Cassette

1. Be sure that the power switch is turned off.
2. Detach the printer cover.
3. Open the auto cutter. (iDP-3551)
4. If the ribbon is slackened, turn the knob in the direction shown by the arrow to give the tension before placing it in the printer.
5. Push the locking claws into the holder of the printer as you place the ribbon between the print head and ribbon guide. A click sound will be heard.
6. Turn the knob of the ribbon cassette in the direction shown by the arrow to eliminate any slackness of the ribbon.
7. To remove the ribbon cassette, lift it while tilting the locking claws inwards. The locking claws are located at both sides.
8. Close the auto cutter. (iDP-3551)
9. Attach the printer cover.

 **CAUTION:** •When closing the auto cutter, do so gently not to give a shock.

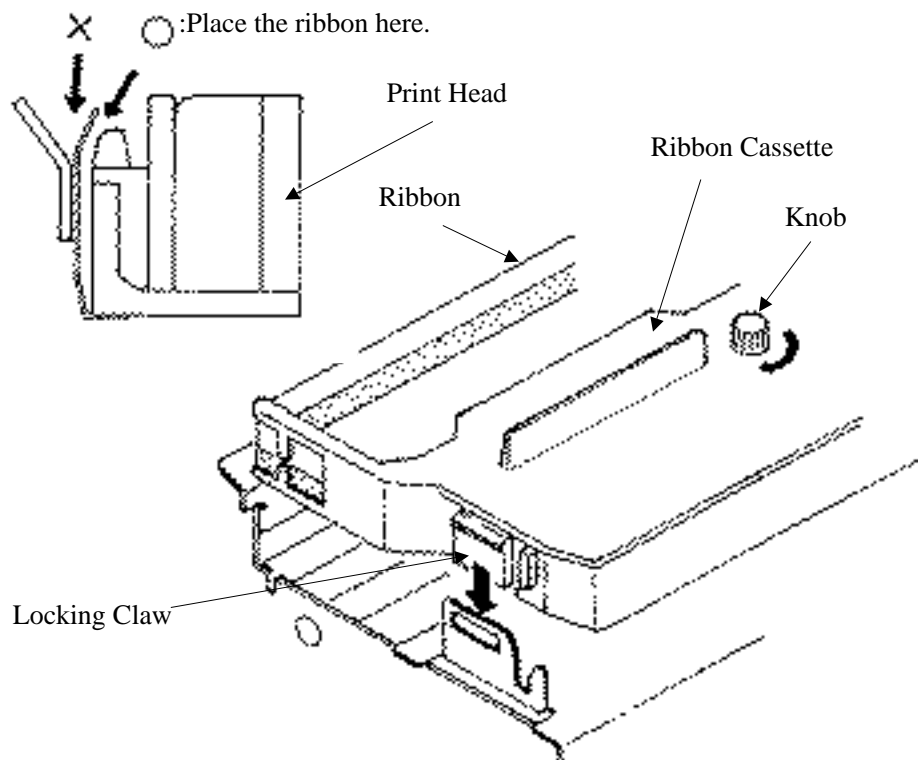

4.6 Inserting the Paper

1. Cut the end of the paper roll at close to a right angle.



CAUTION :

- Be sure to use the specified paper roll.
 - Use of unspecified paper may adversely affect print quality, printer service life, and so on.
 - Do not insert a frayed or bent end of paper into the printer.
2. Check the winding direction of the paper roll. (See the figure on the next page.)
 3. Hold the paper holder open and insert the paper roll so that it is securely supported by the paper holder.
 4. Turn on the printer.

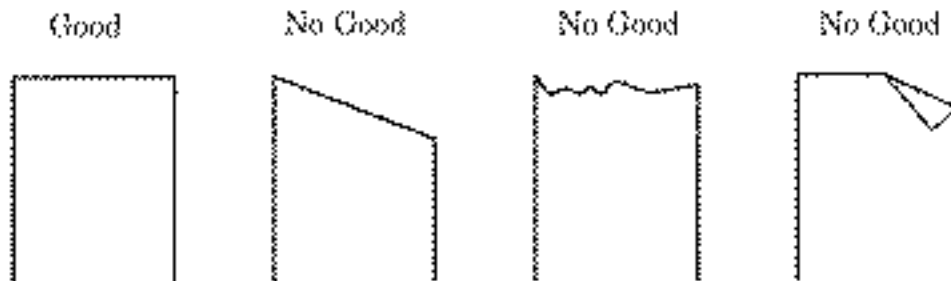

5. Insert the end of the paper roll straight into the paper inlet slot (Indicated by the arrow).
6. The paper is automatically fed in and comes out the paper outlet of the printer (Paper outlet of the auto cutter for the iDP-3551).

You can cut the surplus paper using the tear bar.



CAUTION :

- If the paper is slack, rewind it, to remove the slack.
- While printing, do not hold the paper. This can cause a paper jam.
- When closing the auto cutter, do so gently not to give a shock.

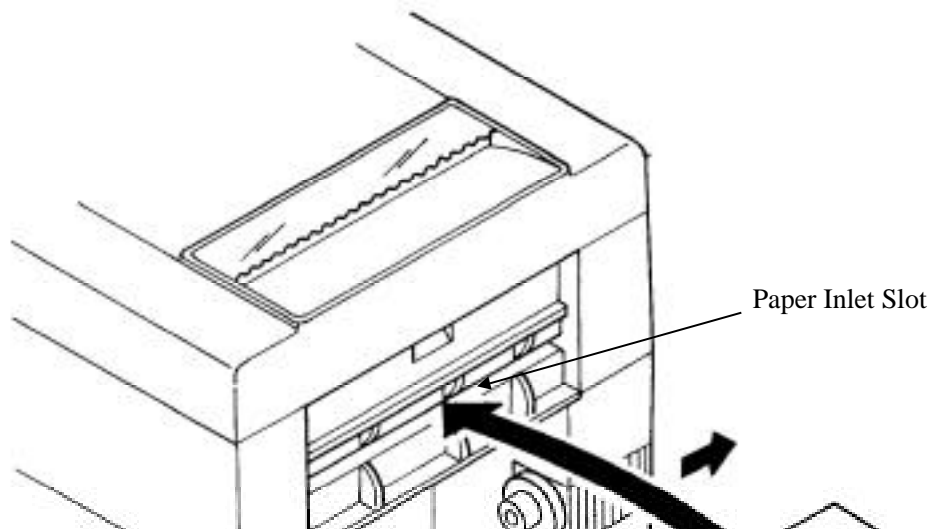

4.7 Attaching the Rear Cover

Insert the claws of the rear cover into the square holes at the back of the printer, and move the rear cover in the direction of the arrow to close it.

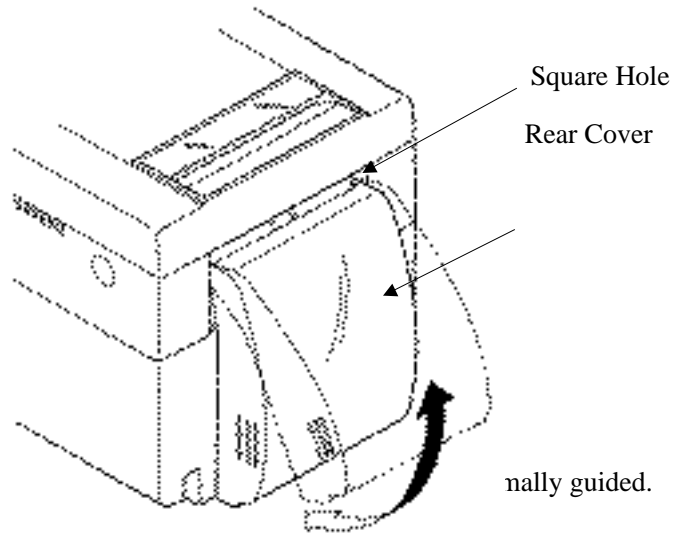

4.8 How to Remove Roll Paper

1. Detach the printer cover.
2. Open the auto cutter.
3. Remove the paper roll.
4. Close the auto cutter.
5. Attach the printer cover.

- CAUTION :** •When removing the paper, do not pull the paper from the paper inlet. (Do not remove the paper in the reverse direction.)
- When closing the auto cutter, do so gently not to give a shock.

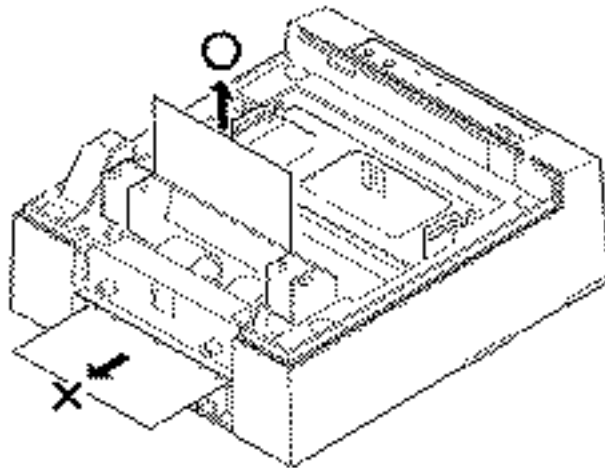

4.9 Removing Paper Jam

1. Detach the printer cover.
2. Cut off the paper near the paper inlet slot.
3. Pull out the paper roll in the ejection direction of paper (NN*).
4. Eliminate completely the paper remaining in the paper route.
5. Attach the printer cover.

- CAUTION :** •When removing the paper, do not pull from the paper inlet. (Do not remove the paper in the reverse direction.)
- When closing the auto cutter, do so gently not to give a shock.

4.10 Unlocking the Cutter (iDP-3551)

1. Detach the printer cover.
2. Press the LF switch. The auto cutter is initialized to return its blade and clear an alarm.
3. If the paper is jamming, eliminate the jamming paper completely, seeing "4.9 Removing Paper Jam."
4. If the alarm still cannot be cleared, turn off the power and open the auto cutter.
5. You can see an emergency knob through a small hole in the back of the auto cutter. Using tweezers, screwdriver, etc., turn the knob in the arrow-indicated direction to return the blade. If there is a paper jam or paper refuse, eliminate it completely.
6. Attach the printer cover.



CAUTION: • When pulling out the paper(Forward/Reverse direction), be sure to operate the paper free lever.

- When closing the auto cutter, do so gently not to give a shock.

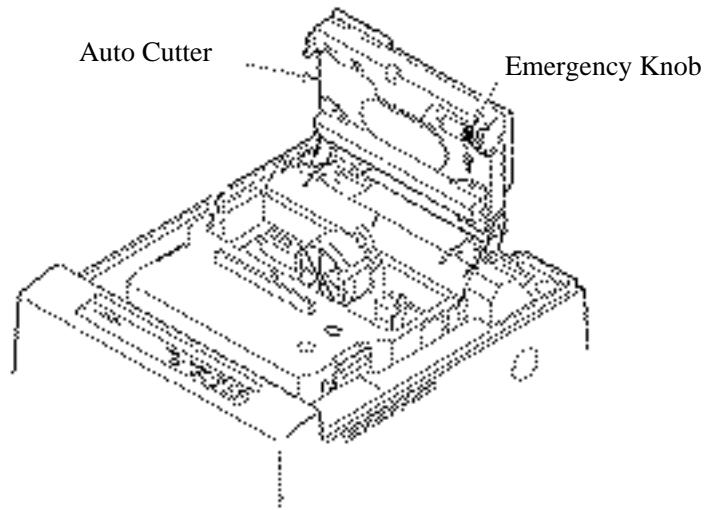

4.11 Operation Panel and Display of Error

1. POWER lamp (Green)

This lamp is illuminated when the power is supplied.

2. ERROR lamp (Red)

This lamp is illuminated or blinks to indicate each error.

Error Indication	SEL/ERROR Lamp	Buzzer	Resetting Method
Mechanical Error	Quick blinking	Sounds continuously for approx. 1 second	Reset the Power switch.
Paper End	Blinks.	Repeats a short 3-time sound twice at intervals of 0.5 second.	Set a new paper roll.
Paper Near End	Blinks. (Once a second)	Repeats a short 3-time sound twice at intervals of 0.5 second.	Set a new paper roll.
Cutter Motor Lock (iDP-3551 only)	Quick blinking (Twice a second)	Sounds continuously for approx. 1 second.	Eliminate a paper jam.

Mechanical Error : If the printer mechanism has a greater load due to a paper jam, etc., the buzzer will sound and the SEL/ERROR lamp will blink to stop the printer mechanism.

Paper End : If the printer has run out of paper, the paper sensor in the paper path near the print head will detect the end of the paper roll, turn on the buzzer, and blink the SEL/ERROR lamp to stop the printer mechanism. If the paper is inserted into the paper path, the paper will be loaded. (See 4.6 Inserting the Paper)

Paper Near End : If the paper is running out, the paper near end sensor will be activated to turn on the buzzer and make the SEL/ERROR lamp blink. Even after the paper near end is detected, a command can be used to print by the specified number of lines. (See a description on the command for setting the number of print lines after paper near end detection)

Cutter Motor Lock (iDP-3551) : If the cutter position detection sensor in the cutter unit is left turned on or off for approx. 1 second while the cutter motor is running, cutter operation and printing will be suspended, determining it to be motor lock.

Backup Data Clear : When the power is turned on, depending on the SEL switch operation, the backup data in the input buffer will be cleared according to the flowchart on the next page.

To clear the input buffer, turn on the power while pressing the SEL switch. The following messages will be printed.

“Clear Data in Buffer”

“Cleared Data in Buffer”

To print the data in the input buffer, simply turn the power on. The following message is printed and the data in the input buffer is printed.

“Power Down(Data in Buffer)”

Test Print : When the power is turned on while the LF switch is pressed, a test print is carried out.

Dump Mode

When the power is turned on while the LF and SEL switches are pressed, the printer enters dump mode and prints the following message.

“=== Hexadecimal Dump ===”

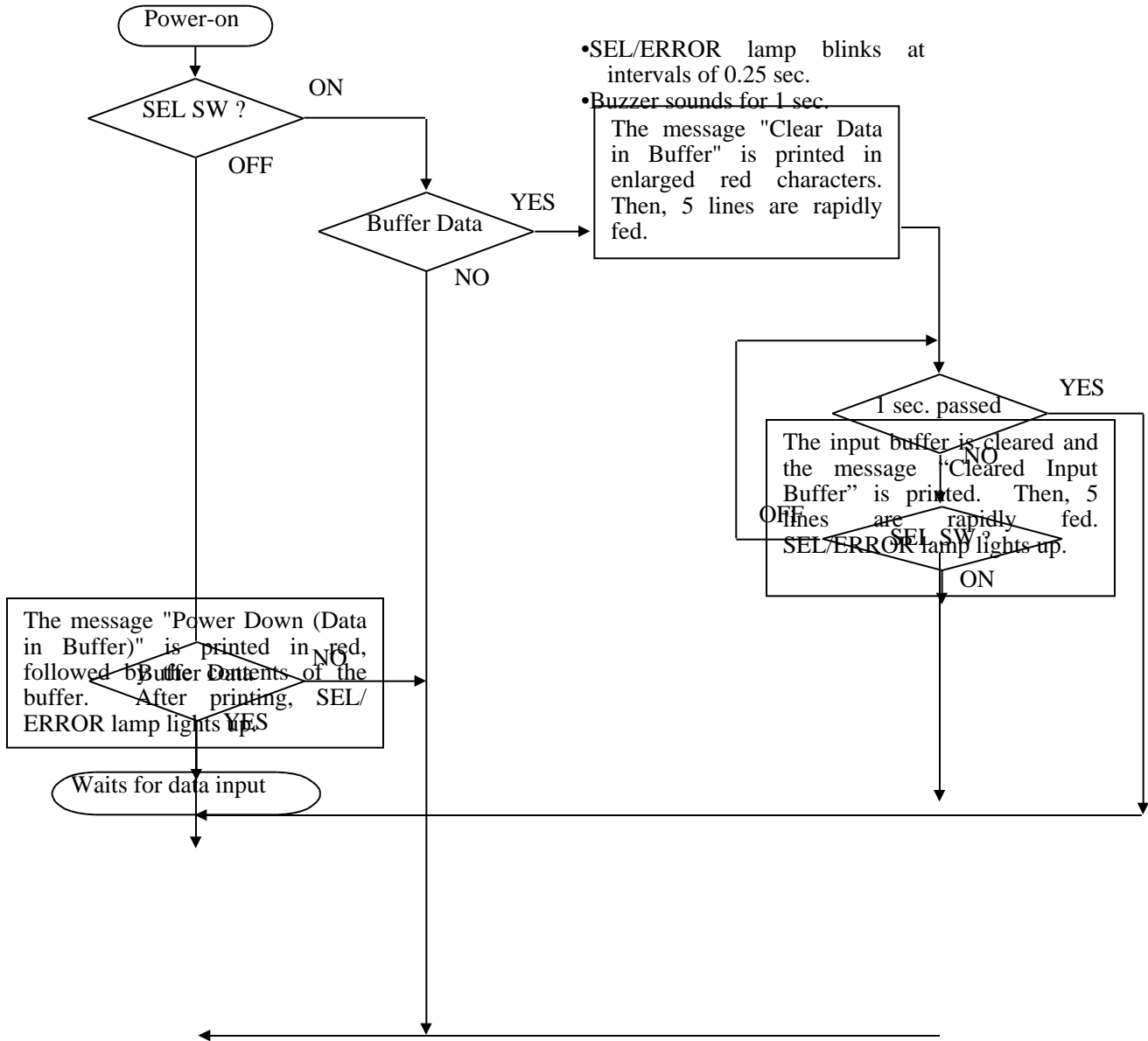

5. DIP SWITCH SETTING

5.1 Location of DIP Switch

1. Turn off the power.
2. Remove the printer cover.
3. The DIP switch can be found at the location shown in the figure below. (Only DSW2 is available for the serial interface.)

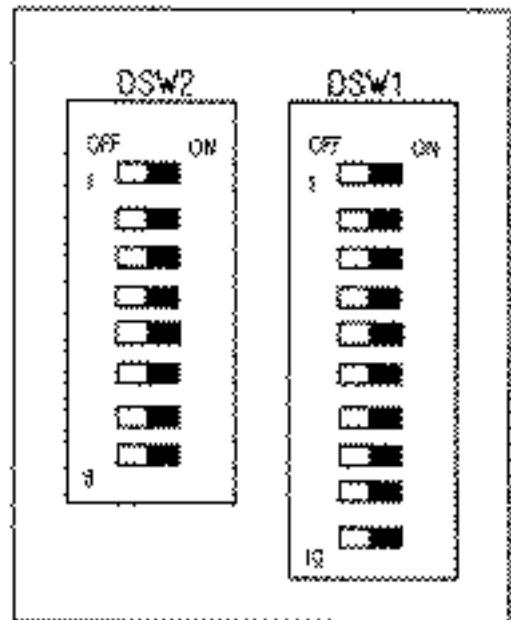
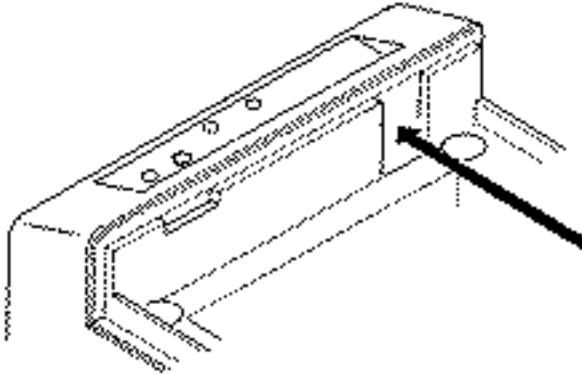

5.2 DIP Switches Setting

1) DIP Switch 1

No.	Function	ON	OFF	Upon Shipment from Factory
DSW1-1	Auto cutter	Yes	No	ON *1
DSW1-2	International characters	See the Table below		ON *2
DSW1-3				ON *2
DSW1-4				ON *2
DSW1-5	CBM command	CBM2 mode (iDP-3530 system)	CBM1 mode (iDP-3540 system)	OFF*4
DSW1-6	CR mode	See the Table below		OFF
DSW1-7	Mechanism type	Graphic	Character	OFF
DSW1-8	Buffer size	6K bytes	256 bytes	ON
DSW1-9	Operation mode	See the table below		OFF *3
DSW1-10				OFF *3

*1, *3 : Depends on the type.

*2 : Depends on the destination.

*4 : Effective only when CBM mode is selected with DSW1-9 and -10. For details see “CBM Mode” in “PRINT CONTROL FUNCTIONS.”

International Character Selection

No. Country	DSW1-2	DSW1-3	DSW1-4
U.S.A.	ON	ON	ON
France	OFF	ON	ON
Germany	ON	OFF	ON
U.K.	OFF	OFF	ON
Denmark	ON	ON	OFF
Sweden	OFF	ON	OFF
Italy	ON	OFF	OFF
Japan	OFF	OFF	OFF

Character Code Selection

	ESC/POS mode	CBM mode	Star mode
→	Code 437	CBM (International)	Star (International)
→	Code 850	Code 850	Code 850
→			
→			
→			
→			
→			
→	Katakana	CBM (Japanese)	Star (Japanese)

See the “International Character Codes Table and Character Codes Table”.

CR mode(DSW1-6)

Mode	OFF	ON
CBM	CR+LF	CR
STAR	CR+LF	Ignored
ESC/POS	CR+LF	CR

Operation Mode DSW1-9 DSW1-10

Mode	DSW1-9	DSW1-10
CBM	OFF	OFF
ESC/POS	ON	OFF
STAR	OFF	ON
STAR Auto cut	ON	ON

2) DIP Switch 2

No.	Function	ON	OFF	Factory Setting
DSW2-1	Bit length	8 bits	7 bits	ON
DSW2-2	Parity	No	Yes	ON
DSW2-3	Odd/Even	Odd	Even	ON
DSW2-4	Communication mode	DTR/DSR	XON/XOFF	ON
DSW2-5	Baud rate	See the table below		ON
DSW2-6				ON
DSW2-7				OFF
DSW2-8	Unused			OFF

Baud rate

Baud rate	DSW2-5	DSW2-6	DSW2-7
150	OFF	OFF	OFF
300	OFF	OFF	ON
600	OFF	ON	OFF
1200	OFF	ON	ON
2400	ON	OFF	OFF
4800	ON	OFF	ON
9600	ON	ON	OFF
19200	ON	ON	ON

The DIP switch 2 is used only for the serial interface.

6. PRESET JUMPER SETTING

6.1 Location of Preset Jumper

- (1) Turn off the power.
- (2) The preset jumper is set at the time of shipment from the factory. If the settings are to be changed, do so by removing the control board and changing the setting as indicated in the service manual. The location of the preset jumpers is shown in the figure below.

Serial Interface

Parallel Interface

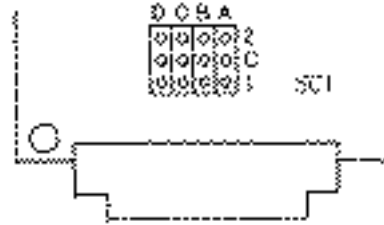

6.2 Preset Jumper

Location	Serial	Parallel	ESC/POS
SC1-A	1-C *	2-C	2-C
SC1-B	1-C *	1-C *	2-C
SC1-C	1-C	2-C	*
SC1-D	1-C	2-C	*
SC1-E	1-C *	2-C	1-C *
SC1-F	1-C *	2-C	1-C *
SC1-G	1-C *	2-C	1-C *
SC1-H	1-C	2-C *	2-C *

* = Open
 1-C * = 1-C or open
 2-C * = 2-C or open

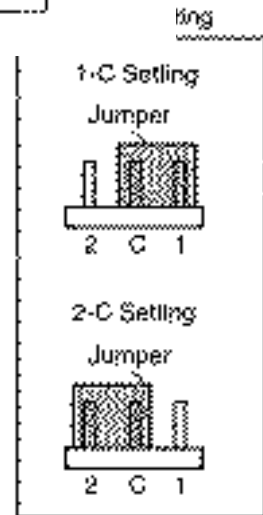

Parallel Interface

Location	Mode	CBM	STAR	ESC/POS
SC1-A		1-C *	1-C	2-C *
SC1-B		1-C	1-C	2-C
SC1-C		1-C *	1-C *	2-C
SC1-D		1-C	1-C	2-C *

* = Open
 1-C * = 1-C or open
 2-C * = 2-C or open

7. MODE SETTING METHOD

This printer has the CBM, STAR, and ESC/POS mode. Any desired mode can be selected and set according to your need.

(1) Setting method

- See 5 “DIP SWITCH SETTING”.
- Seeing the settings of the DIP switch segments 1-9 and 1-10 and those of the preset jumper, set each mode.

8. INPUT BUFFER BACKUP FUNCTION

8.1 Buffer Size

With the DIP switch, you can set either 6 K bytes or 256 bytes.

DIP switch segment 1-8	ON	6K bytes
	OFF	256 bytes

8.2 Input Buffer Backup

Even if the power is turned off or fails during the printing process, the data in the input buffer will be saved. If the power is turned on again, the printer will print a power failure mark, "==POWER DOWN==" in red and reprints the data from the beginning of the line where it left off.

8.3 Clearing the Input Buffer

When you want to clear the data in the input buffer, turn on the power while holding down the SEL switch. The following messages will be printed to notify that the input buffer is cleared.

“Clear Data in Buffer”

“Cleared Data in Buffer”

If the printer prints the data erroneously at power-on, clear the input buffer as described above, and then, re-input the data.

9. PARALLEL INTERFACE

9.1 Specifications

- Data input system : 8-bit parallel system (DATA1 to DATA8)
- Control signals : ACK, BUSY, STB, FAULT, SELECT, RESET, COMPULSION
- Applicable connectors : Printer side --- 57LE-40360 (Anphenol), or equivalent
Cable side --- 57-30360 (Anphenol), or equivalent

9.2 Connector's Pin Configuration

Mode No.	CBM	STAR	ESC/POS	Mode No.	CBM	STAR	ESC/POS
1	STB			19	TWISTED PAIR GND		
2	DATA 1			20			
3	DATA 2			21			
4	DATA 3			22			
5	DATA 4			23			
6	DATA 5			24			
7	DATA 6			25			
8	DATA 7			26			
9	DATA 8			27			
10	ACK			28			
11	BUSY			29			
12	PE(HI-LEVEL)			30			
13	SELECT			31	RESET		
14	GND			32	FAULT		GND
15	GND	NC		33	NC		
16	GND	NC		34	COMPULSION		
17	FRAME GND			35	NC		Vcc
18	Vcc		NC	36	Vcc		NC

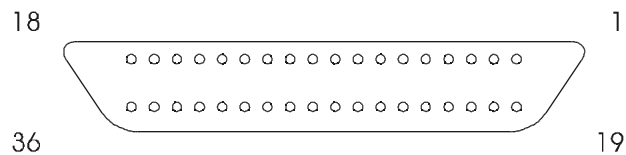

9.3 Input and Output Signals

9.3.1 Input and Output Signals

(1) Input signals to the printer

- DATA : An 8-bit parallel signal. (Active “High”)
- \overline{STB} : A strobe signal to read the 8-bit data. (Active “Low”)
- \overline{RESET} : A signal to reset the printer from the outside. (Active “Low”)

(2) Output signals from the printer

- \overline{ACK} : An 8-bit data request signal. A pulse signal output at the end of the BUSY signal. (Active “Low”)
- BUSY : A signal to indicate the BUSY status of the printer. Input new data when at "Low". (Active “High”)
- \overline{FAULT} : A signal turned to "Low" when the printer has an alarm. At this time, all the control circuits in the printer stop. (Active “Low”)
- SELECT : A signal to show whether the printer is selected (On-line) or deselected. (Active “High”)
- COMPULSION : A signal to show the status of the drawer switch. (Active “High”)
- PE : A signal to show that the paper has run out. Normal at the "Low" level, but turned to the "High" level when the paper has run out.

(3) Power related signal

- GND : Common ground on the circuits
- Vcc : A +5 V signal. Connected via a 3.3k resistor. (Factory use only)

9.3.2 Electrical Characteristics

- (1) Input signal level
All the input signals are at the TTL level.
"HIGH" level : 2.0 V at minimum
"LOW" level : 0.8 V at maximum
- (2) Output signal level
All the output signals are at the TTL level.
"HIGH" level : 2.4 V at minimum
"LOW" level : 0.4 V at maximum
- (3) Input and output conditions
All the input signals are pulled up with a 3.3 k resistor.

[Printer Side]

[Host Side]

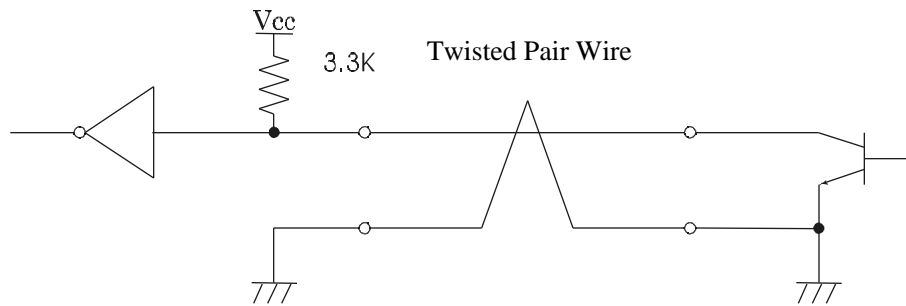

All the output signals are pulled up with a 3.3k resistor.

[Printer Side]

[Host Side]

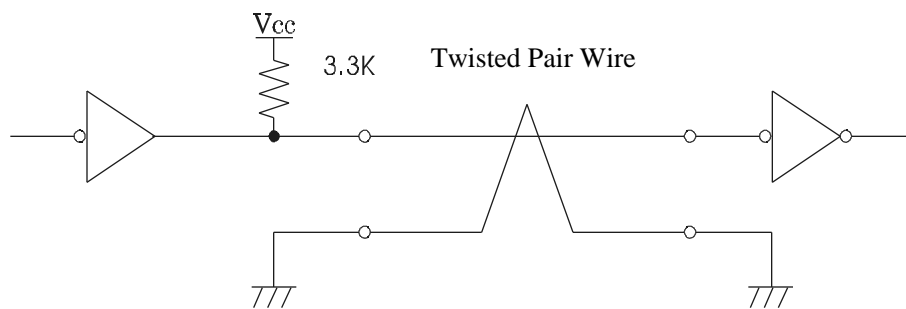

9.3.3 Timing Chart

(1) Data input and printing timing

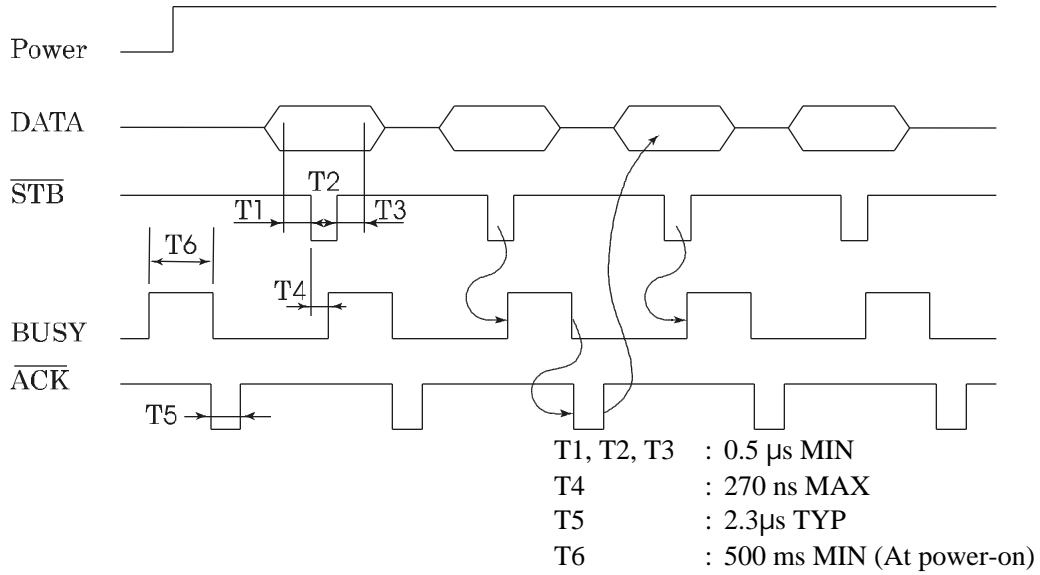

9.3.4 Data Receiving Control

When the BUSY signal is at "LOW," the printer can receive the data from the host, but when at "HIGH," it cannot.

10. SERIAL INTERFACE

10.1 Specifications

- (1) Synchronous system: Asynchronous
- (2) Baud rate: 150, 300, 600, 1200, 2400, 4800, 9600, or 19200 bps (User selectable)
- (3) Configuration of one word
 - Start bit : 1 bit
 - Data bits : 7 or 8 bits (User selectable)
 - Parity bit : Odd, even, or none (User selectable)
 - Stop bit : 1 bit or more
- (4) Signal polarity
RS-232C
 - Mark = Logic "1" (-3 V to -12 V)
 - Space = Logic "0" (+3 V to +12 V)
- (5) Received data (RXD signal)
RS-232C
 - Mark = 1
 - Space = 0
- (6) Reception control (DTR signal)
RS-232C
 - Mark : Data transfer disabled
 - Space : Data transfer enabled

10.2 Connector's Pin Configuration

Mode No.	CBM	STAR	ECS/POS
1	FG		
2	TXD		
3	RXD		
4		RTS	
5			
6			DSR
7	GND		
8			
9			
10			
11	PE (HI-LEVEL)	RCH	
12	FAULT		
13		GND	
14		FAULT	
15		mTXD	
16		mRXD	
17			
18			
19			
20	DTR		
21			
22			
23	RESET		
24			
25			

The diagram shows a 25-pin connector with two rows of pins. The top row has pins numbered 13, 1, and 14. The bottom row has pins numbered 25 and 14. The connector is represented by a rounded rectangle with small circles inside representing the pins.

- Cautions:
1. An RS-232C signal is based on the EIA RS-232C.
 2. When the data is not being transferred, the received data should be always maintained as a mark.

10.3 Input and Output Signals

10.3.1 Input and Output Signals

- (1) RXD
This is a serial received data signal. When a framing error, overrun error, or parity error occurs, that data is printed as "?".
- (2) DTR
When this signal is Ready, write the data or a command. If written at the time of Busy, an overrun error results, ignoring the previous data. The data can be written in the input buffer even during printing. Busy is also issued at the time of power-on, test print, on-line, and reset.
- (3) TXD
XON (11H) or XOFF (13H) is sent at XON/XOFF control. XON (11H) is sent every 3 seconds in the STAR mode.
When a command is received, that requests the printer state and printer status, 1-byte corresponding data is output.
- (4) DSR
When this signal is a space, the data is sent from the printer side. Note that if this signal is a mark when a request to send command is executed, the printer will wait until the signal becomes a space.
- (5) FAULT
 - ★ CBM mode
When this signal is Space, a mechanical error has occurred.
 - ★ STAR mode
When this signal is Mark, a mechanical error has occurred.
- (6) $\overline{\text{RESET}}$
A signal to reset the entire printer. (Active Low)
- (7) RTS
This signal is turned to Space when the printer is turned on.

- (8) RCH
When the printer is ready to receive, this signal is turned to Space. This signal line is the same as DTR.
- (9) mTXD
TXD signal for the diode gate.
- (10) mRXD
RXD signal for the diode gate.
- (11) FG
This is a Frame Ground signal.
- (12) GND
This is a common ground on the circuit.

10.3.2 Data Configuration

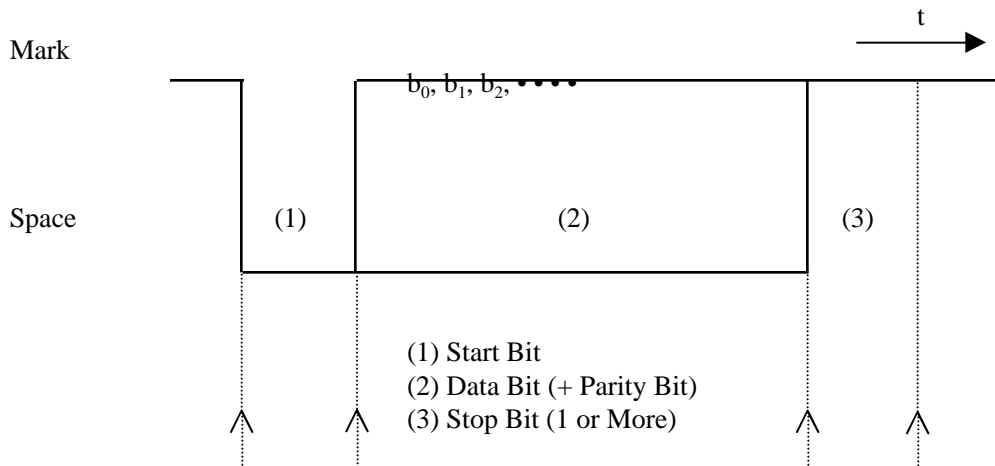

(1) Start bit

After a lapse of 1/2 bit from a mark-to-space fall edge, the state is read again, and if it is a space, it is recognized as the start bit. If it is a mark, it is assumed neither the start bit nor an error, and it is attempted to detect the start bit again.

(2) Data bit + parity bit

The data bit and parity bit are sampled for 1 bit worth of time from the 1/2 start bit. The then state is assumed the data for the corresponding bit. A sequence of the bits are named Bit 0, Bit 1, ..., parity bit, starting from the one closest to the start bit.

(3) Stop bit

The stop bit is a mark level of 1 bit or more. If a space is detected in detecting the stop bit, a framing error results.

10.3.3 Error Detection

A parity error, framing error, and overrun error are detected. When an error is detected, that data is stored in the buffer as "?".

- (1) Framing error
This error results when a space is detected in detecting the stop bit. That data is stored in the buffer as "?".
- (2) Parity error
If a parity check has been specified and an error is detected at the time of parity check, that data is stored in the buffer as "?".
- (3) Overrun error
If an overrun error is detected, that data is stored in the buffer as "?".

10.3.4 Data Receiving Control

When the DTR signal is a space, the data from the host side can be received. When it is a mark, however, the data cannot be received.

10.3.5 Buffering

The DTR and TXD signals are available as control signals to transfer the data to the input buffer.

10.3.6 Electrical Characteristics

- (1) RS-232C circuit
Input (RXD, DSR, mRXD)

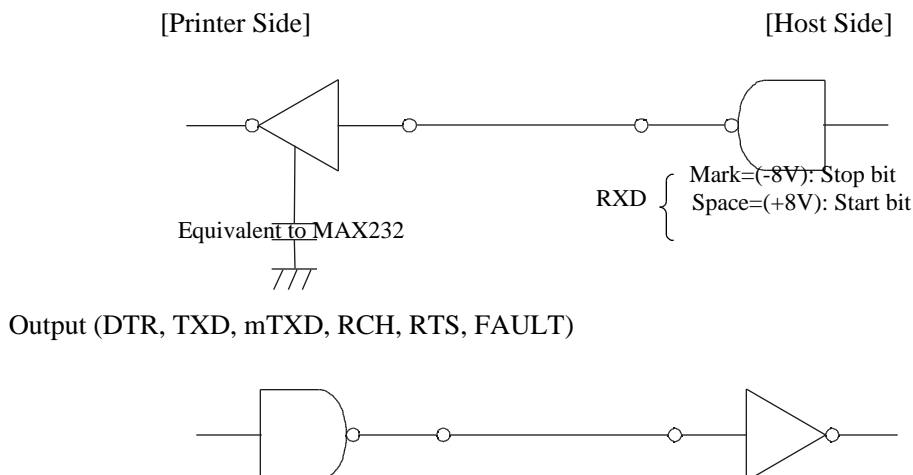

	Equivalent to MAX232		
DTR	{ Mark=(-8V): At Busy Space=(+8V): At Ready }	TXD	Mark=(-8V): 1 Space=(+8V): 0

(2) Others

- $\overline{\text{RESET}}$: A signal to reset the entire printer.
- PE : A signal to show that the paper has run out. Normal at the "LOW" level, but turned to the "HIGH" level when the paper has run out.
- GND : Signal ground
- FG : Frame ground

11. DRAWER KICK-OUT CONNECTOR

11.1 Specifications of Drawer Kick-Out Connector

- (1) Drawer kick-out drive signal
 - Parallel ----- Can be learned at the no. 34 pin of the interface connector
 - Serial ----- Provided with a command to learn the status in the STAR and ESC/POS modes.

- (2) Electrical characteristics
 - 1) Drive voltage: 24 V DC
 - 2) Drive current: 0.8 A at maximum (Within 510 ms)
 - 3) Switch signal: Signal level "L" = 0 to 0.5 V
"H" = 3 to 5 V

11.2 Connector's Pin Configuration

No.	Signal	Function
1	FG	Frame Ground
2	DRAWER 1	Drawer 1 drive signal
3	DRSW	Drawer switch input
4	VDR	Drawer drive power
5	DRAWER 2	Drawer 2 drive signal
6	GND	Common ground on the circuit

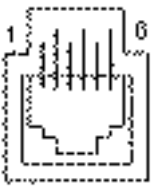

Connector used : TM5RJ3-66 (HIROSE)

Applicable connector : TM3P-66P (HIROSE) or equivalent



- CAUTION :**
- No output is made while printing.
 - The drawers 1 and 2 cannot be driven simultaneously.
 - A solenoid used for the drawer should be of 36 or more. An output current should be kept below 0.8 A. Use beyond this limit cannot be assured.
 - This connector cannot be connected to a telephone line. Do not connect other than the solenoid.

11.3 Drive Circuit

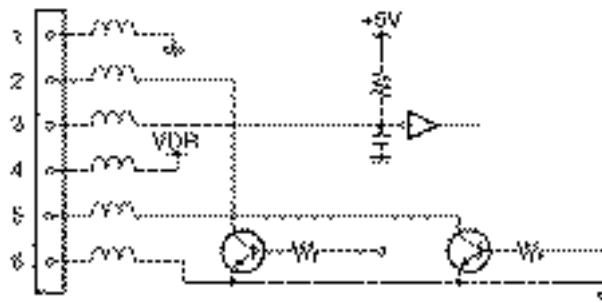

12. WINDER CONNECTOR

12.1 Specifications of Winder Connector

- (1) Winder drive signal
The winder drive signal is output synchronous with the LF signal.
- (2) Electrical characteristics
 - 1) Drive voltage: 24 V DC
 - 2) Drive current: 0.8 A at maximum

12.2 Connector's Pin Configuration

No.	Signal	Function
1	VPX	Winder drive power
2	WD	Winder drive signal
3	FG	Frame Ground
4	FG	Frame Ground

Connector used : 5045-04A (MOLEX)
Applicable connector : 5209-04 (MOLEX) or equivalent



CAUTION : • This connector shall be used for Auto Winder AW-3 only.
Do not connect any other device.

12.3 Drive Circuit

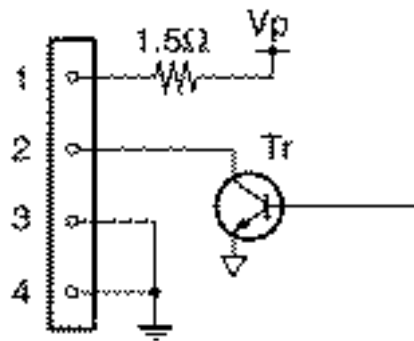

13. MAINTENANCE AND SERVICE

For the information on maintenance and service, please contact our dealer or at the following address.

Northern America

CBM America Corporation
Service Center
365 Van Ness Way
Suit 510
Torrance, CA 90501, U.S.A

Japan

Other Areas

Japan CBM Corporation
Information Systems Division
CBM Bldg., 5-68-10, Nakano
Nakano-ku, Tokyo 164-0001

TEL +1-310-781-1460

FAX +1-310-781-9157

TEL +81-3-5345-7540

FAX +81-3-5345-7541

14. PRINT CONTROL FUNCTIONS

14.1 CBM Mode

14.1.1 Command List

	Command	Function	Code	Page
1	FF n	n-line paper feed (CBM1 mode)	0CH n	40
2	FF	CBM2: Form feed (CBM2 mode)	0CH	40
3	SO (Note)	Specifying the double width character	0EH	41
4	SI (Note)	Canceling the double width character	0FH	41
5	LF	Printing and paper feed	0AH	41
6	CR	Printing	0DH	41
7	DC 1 (Note)	Initializing the printer	11H	42
8	DC 2 (Note)	Specifying/Canceling the Inverted character	12H	42
9	DC 3 (Note)	Specifying the red print	13H	44
10	CAN	Canceling the print data	18H	45
11	ESC * n1 n2	Specifying the bit image mode	1BH 2AH n1 n2	46
12	ESC - n	Specifying/Canceling the Underline	1BH 2DH n	46
13	ESC 1	Specifying 1/9-inch line feed width	1BH 31H	47
14	ESC 2	Specifying 2/9-inch line feed width	1BH 32H	47
15	ESC 3	Specifying standard line feed width	1BH 33H	47
16	ESC C n	Setting the page length	1BH 43H n	47
17	ESC N n	Specifying the perforation skip	1BH 4EH n	49
18	ESC O	Canceling the perforation skip	1BH 4FH	49
19	ESC f 1	Form feed (Changing the page)	1BH 66H 01H	49
20	ESC t n	Selecting the character code table	1BH 74H n	50
21	ESC BEL n1 n2	Setting the external device drive pulse width	1BH 07H n1 n2	51
22	BEL	Driving command A for Drawer-1	07H	51
23	FS	Driving command B for Drawer-1	1CH	52
24	SUB	Driving command for Drawer-2	1AH	52
25	RS	Buzzer-on	1EH	52
26	ESC P 0	Full cut	1BH 50H 00H	53
27	ESC P 1	Partial cut	1BH 50H 01H	53
28	ESC R n	Selecting the international character set	1BH 52H n	53
29	ESC & 0 n1 n2	Defining the download character set	1BH 26H 00H n1 n2	54
30	ESC % n	Specifying/Canceling download character set	1BH 25H n	55
31	ESC /n	Definition the message	1BH 2FH n	55
32	ESC DC3 n	Printing the message	1BH 13H n	56
33	ESC y n	Setting the print lines after paper near end detection	1BH 79H n	56
34	ESC DC2 n1 n2	Deleting the download character, message, bit image	1BH 12H n1 n2	57
35	GS n1 n2	Defining the download bit image	1DH 2AH n1 n2	58
36	GS /m	Printing the download bit image	1DH 2FH m	59

Note: Effective when CBM mode is selected with the DIP switch segments 1-9 and 1-10 and CMB1 (OFF) is

selected with the DIP switch segment 1-5. If CBM2 (ON) is selected with the DIP switch segment 1-5, the functions of these commands are changed as shown in the table below.

Command	Code	Function	
		8-bit data selected	7-bit data selected
SO	0E	Canceling the double width character	SO side character
SI	0F	Specifying the double width character	SI side character

Command	Code	Function
DC1	11	Selecting the printer
DC2	12	Specifying the red print
DC3	13	Deselecting the printer

14.1.2 Description of Items

XXXX

ALL

[Function]	Command name
[Code]	A row of command constituent code is represented by a hexadecimal number with <>H, binary number with <>B, and a decimal number with <>. []k means a repeat count of k-times.
[Range]	Describes an argument value (Setting range) for the command.
[Outline]	Describes a command function.
[Caution]	Describes a caution as required.
[Default]	Describes an initial value for the command when accompanied by an argument.
XXX	Shows a command.

Details

~~FF n~~ (CBM1 Mode)

[Function]	n-line paper feed
[Code]	<0C>H n
[Range]	1 n 127
[Outline]	This command feeds the paper by n-lines. You can set n = 1 to 127 lines. If the print buffer contains the data, use of this command feeds the paper by n-lines after printing the data. Setting n = 0 does not feed the paper.

~~FF~~ (CBM2 Mode)

[Function]	Form feed
[Code]	<0C>H
[Outline]	This command searches for the beginning of the next page after printing the data in the print buffer.

SO (CBM1 Mode)

[Function]	Specifying the double width character
[Code]	<0E>H
[Outline]	The data following this command is printed doubled in the horizontal direction. Double width characters remain valid until the double width character cancel command is entered, but they are also cancelled after they are printed one line. Note that the double width characters take up two ordinary characters worth of width.

SO (CBM2 Mode)

[Function]	Specifying the double width character/shift-out side characters
[Code]	<0E>H
[Outline]	The data following this command is printed doubled in the horizontal direction. Double width characters remain valid until the double width character cancel command is entered, but they are also cancelled after they are printed one line. Note that the double width characters take up two ordinary characters worth of width. In the case of a serial interface, if 7-bit data is selected, the shift-out side character is printed.

~~SI~~ (CBM1 Mode)

[Function]	Canceling the double width character
[Code]	<0F>H

[Outline] This command cancels the double width characters set with SO. The data following this command are printed in the ordinary character width.

~~SI~~ ~~(CBM2 Mode)~~

[Function] Canceling the double width character/Specifying the shift-in side characters

[Code] <0F>H

[Outline] This command cancels the double width characters set with SO. The data following this command are printed in the ordinary character width.
In the case of a serial interface, if 7-bit data is selected, the shift-in side character is printed.

LF

[Function] Printing and paper feed

[Code] <0A>H

[Outline] If the print buffer contains the data, this command will feed the line after printing. If not, the command only feeds the line.

CR

[Function] Printing

[Code] <0D>H

[Outline] This command prints the data. If the DIP switch segment 1-6 is set to OFF, the printer will print the data in the print buffer and feed the paper by one line.
If it is set to ON, the printer will print the data in the print buffer and will not feed the paper.

~~DC1~~ ~~(CBM1 Mode)~~

[Function] Initializing the printer

[Code] <11>H

[Outline] This command initializes the printer.
The input buffer is not cleared.
The settings of the DIP switch segments are not re-read.

DC1 ~~(CBM2 Mode)~~

- [Function] Selecting the printer
- [Code] <11>H
- [Outline] This command sets the printer in the selecting status.

DC2 (CBM1 Mode)

- [Function] Specifying/Canceling the inverted character
- [Code] <12>H
- [Outline] This command selects/deselects the inverted characters. Enter this command at the beginning of one line. Otherwise, it is overridden. Erect and inverted characters cannot be mixed in one line.

DC2 (CBM2 Mode)

- [Function] Specifying the red print
- [Code] <12>H
- [Outline] This command specifies red-color characters. All the characters in one line are printed in red by prefixing the print data with this command and sending it to the printer. When you want to use red characters, use this command for each line.

DC3

(CBM1 Mode)

[Function]	Specifying the red print
[Code]	<13>H
[Outline]	This command specifies red-color characters. All the characters in one line are printed in red by prefixing the print data with this command and sending it to the printer. When you want to use red characters, use this command for each line.

DC3

(CBM2 Mode)

[Function]	Deselecting the printer
[Code]	<13>H
[Outline]	This command sets the printer in the deselecting status in which the printer cannot receive data. To set the printer in the selecting status, use DC1.

~~CAN~~

[Function]	Canceling the print data
[Code]	<18>H
[Outline]	This command clears the print data in the lines entered prior to this command.

ESC " " n1 n2

[Function]	Specifying the bit image mode
[Code]	<1B>H <2A>H n1 n2
[Range]	1 n1 + 256 × n2 360 (for DP654 mechanism) 1 n1 + 256 × n2 400 (for DP657 mechanism)
[Outline]	This command allows printing in the bit image mode. Divide the number of dots printed by 256 and assume its quotient to be n2 and remainder to be n1. Therefore, the number of horizontal dots will be n1 + 256 × n2. If the bit image data is entered beyond the dot positions printable in one line, the surplus data will be discarded. Normal data processing is restored after bit image printing. Printing is done in a single direction.

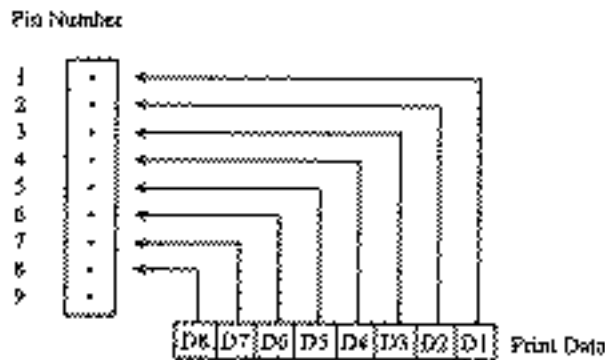

ESC "-" n

[Function]	S
[Code]	<1B>H <2D>H n
[Outline]	This command selects/deselects an underline. The underline is selected at n = 1 and deselected at n = 0.

[Default] n = 0
ESC "1"

[Function]	Setting the 1/9-inch line feed width
[Code]	<1B>H <31>H
[Outline]	Only effective for Graphic type. This command sets the line feed width to 1/9 inch.

ESC "2"

[Function]	Setting the 2/9-inch line feed width
[Code]	<1B>H <32>H

[Outline] Only effective for Graphic type.
This command sets the line feed width to 2/9 inch.

ESC "3"

[Function] Setting the standard line feed width

[Code] <1B>H <33>H

[Outline] This command sets the line feed width as follows.
Character type: 1/6 inch
Graphic type: 2/9 inch

ESC "C" n

[Function]	Setting the page length
[Code]	<1B>H <43>H n
[Range]	1 n 127
[Outline]	Sets the 1-page length to n-lines.

ESC "N" n

[Function]	Specifying the perforation skip
[Code]	<1B>H <4E>H n
[Range]	1 n 126
[Outline]	This command feeds (skips) the lines specified with n without printing. However, you cannot specify beyond the length of one page.

ESC "O"

[Function]	Canceling the perforation skip
[Code]	<1B>H <4F>H
[Outline]	This command cancels perforation skipping operation.

ESC "f" 1

[Function]	Form feed (Changing the page)
[Code]	<1B>H <66>H <01>H
[Outline]	This command searches for the beginning of the next page after printing the data in the print buffer.

ESC "t" n

[Function]	Selecting the character code table
[Code]	<1B>H <74>H n
[Range]	0 n 255
[Outline]	This command selects Page-n of Character Code Table.
[Default]	Depends upon DIP switch setting.

n	Character Code Table	n	Character Code Table
0	CBM International	6	Code Page 852 (Eastern Europe)
1	CBM Domestic	7	Code Page 866 (Russia)
2	Code Page 850 (Multilingual)	8	Code Page 857 (Turkey)
3	Code Page 860 (Portugal)	9	Windows Code
4	Code Page 863 (Canada-French)		
5	Code Page 865 (Norway)	255	Space Page (For user setting)

~~ESC BEL n1 n2~~

[Function]	Setting the external device drive pulse width
[Code]	<1B>H <07>H n1 n2
[Range]	1 n1 127 1 n2 127
[Outline]	This command sets the power-on time to drive an external device (such as cash drawer). Power-on time = $n1 \times 10$ (ms) Delay time = $n2 \times 10$ (ms) To actually drive the drawer, use the BEL and FS commands.
[Default]	$n1 = n2 = 20$

BEL

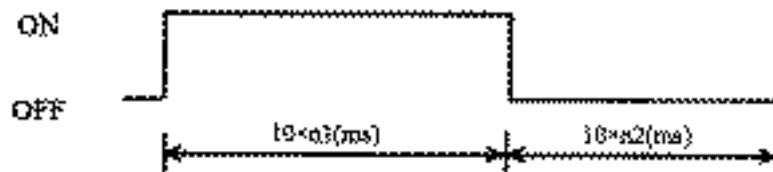

[Function]	Driving command A for drawer-1
[Code]	<07>H
[Outline]	This command drives the drawer connector No. 2 pin under the condition set with the ESC BEL n1 n2 command. This command is executed in order of entry into the input buffer.

~~ES~~

[Function] Driving command B for drawer-1

[Code] <1C>H

[Outline] This command drives the drawer connector No. 2 pin under the condition set with the ESC BEL n1 n2 command.

SUB

[Function] Driving command for drawer-2

[Code] <1A>H

[Outline] As soon as this command is received, the drawer connector No. 5 pin is driven. The power-on time is 200 ms ON and 200 ms OFF stationary. The drawers 1 and 2 cannot be driven simultaneously.

RS

[Function] Buzzer-on

[Code] <1E>H

[Outline] This command emits a short warning sound from the printer.

~~ESC "P" 0~~

~~(iDP-3551)~~

- [Function] Full cut
- [Code] <1B>H<50>H<00>H
- [Outline] This command fully cuts the paper.

ESC "P" 1

(iDP-3551)

-
- [Function] Partial cut
- [Code] <1B>H<50>H<01>H
- [Outline] This command partially cuts the paper.

~~ESC "R" n~~

- [Function] Selecting the international character set
- [Code] <1B>H <52>H n
- [Range] 0 n 10
- [Outline] This command selects the international characters according to the value of n.

n	Character Set	n	Character Set
0	U.S.A.	6	Italy
1	France	7	Spain
2	Germany	8	Japan
3	U.K.	9	Norway
4	Denmark I	10	Denmark II
5	Sweden		

- [Default] Depends upon DIP switch setting.

~~ESC "&" <0> n1 n2 [m0 m1 ... m5 m6 m7 m8 m9] n2 - n1 + 1~~

[Function] Defining the Download character set

[Code] <1B>H <26>H <00>H n1 n2 [m0 m1 ... m5 m6 m7 m8 m9] n2 - n1 + 1

[Range] 32 n1 n2 255 m0 = 0 or m0 = 128

[Outline] This command defines the download characters. n1 is a character code to start definition and n2 is to end definition, respectively. When defining only one character, set n1 = n2. You can define the ASCII codes ranging from 32 to 255. Once the download characters are defined, they remain valid until they are redefined or the download deletion command (ESC DC2 n1 n2) is executed.

When m0=00H

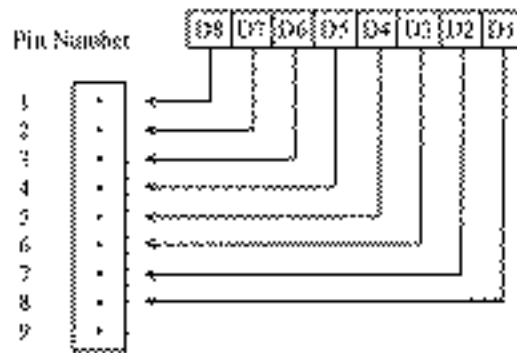

When m0=001H

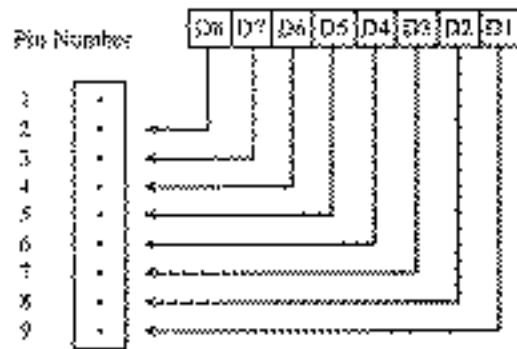

Horizontal adjacent dots cannot be printed.

~~ESC "% " n~~

- [Function] Specifying/Canceling the download character set
- [Code] <1B>H <25>H n
- [Outline] This command selects/deselects the download character set. The download characters cannot be printed by simply defining them with the above-mentioned ESC & 0 command. To print them, send this command to the printer.

n	Download Character Set
0	Deselects
30	
1	Selects
31	

ESC "/" n "data" CR or LF

- [Function] Defining the Message
- [Code] <1B>H <2F>H n "data" CR or LF
- [Range] 1 n 10
- [Outline] This command can define up to a 50-byte message in one line. If the value of n is specified beyond the range, the data following n will be treated as the print data. Once the message is defined, it remains valid until it is redefined. The data should end with CR (0DH) or LF (0AH). If the data exceeds 50 bytes, the subsequent data will be treated as the print data. Once the message is defined, it remains valid until it is redefined or the download deletion command (ESC DC2 n1 n2) is executed.

~~ESC DC3 n~~

[Function] Printing the message

[Code] <1B>H <13>H n

[Range] 1 n 10

[Function] This command prints a message. If the value of n is specified beyond the range, the message will not be printed.

ESC "y" n

[Function] Setting the print lines after paper near end detection

[Code] <1B>H<79>H n

[Range] 0 n1 255

[Outline] This command sets the number of print lines after paper near end detection. It stops printing after printing $n \times 2$ lines since detection of the paper near end, resulting in the paper near end state (See 4.11 Operation Panel and Display of Error). The PE signal (serial/parallel) changes when the paper near end is detected.

[Default] n = 0

~~ESC DC2 n1 n2~~

[Function] Deleting the download character, message, bit image

[Code] <1B>H <12>H n1 n2

[Range] 0 n1 3
0 n2 (Specify 0 at n1 = 0)
(1 n2 10 at n1 = 1)
(32 n2 255 at n1 = 2)
(Specify 0 at n1 = 3)

[Outline] This command deletes the downloaded characters, message, and bit image.

n1	Object Deleted
0	All(Message, characters, bit image)
1	Download message
2	Download characters
3	Download bit image

With n2, specify which data of the function specified with n1 should be deleted.

n2 = 0 Deletes all the data saved with the download function specified with n1.

n2 0 Deletes the data downloaded at the value specified with n2 (Value specified when saving with each download command), of the download function specified with n1.

GS "*" n1 n2 [d] n1 × n2 × 8

[Function] Defining the download bit image

[Code] <1D>H <2A>H <n1> <n2> [<d>] n1 × n2 × 8

[Range] 1 n1 45 0 n2 24

Note) Take care that the number of data (n1×n2×8) is equal to or smaller than 2,048.

[Outline] This command defines the download bit image having the dots specified n1 and n2. The number of horizontal dots is represented by n1 × 8 and that of vertical dots is represented by n2 × 8, respectively. d denotes the number to be registered. (See a download bit image printout.) d denotes the bit image data. Once the download bit image is defined, it remains valid until it is redefined or the download deletion command (ESC DC2 n1 n2) is executed.

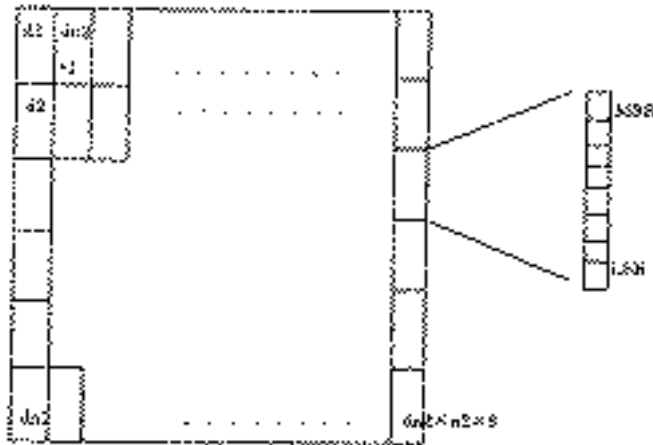

~~GS "/" m~~

[Function] Printing the download bit image

[Code] <1D>H <2F>H m

[Range] 0 m 255

[Outline] This command prints the bit image saved in the number specified with m.

[Caution] If the print buffer contains the data, this command will be ignored. If the bit image has not been saved in the specified number, this command will be ignored.
Nothing is printed when m is other than 0,1,2 or 3.

14.2 STAR Mode

14.2.1 Command List

	Command	Function	Code	Page
1	ESC R n	Selecting the international character set	1BH 52H n	62
2	ESC 6	NOP	1BH 36H	
3	ESC 7	NOP	1BH 37H	
4	ESC M	NOP	1BH 4DH	
5	ESC P	NOP	1BH 50H	
6	ESC :	NOP	1BH 3AH	
7	SO	Specifying the double width character	0EH	62
8	DC4	Canceling the double width character	14H	63
9	ESC E	Specifying the highlight character	1BH 45H	63
10	ESC F	Canceling the highlight character	1BH 46H	63
11	ESC -	Specifying/Canceling the underline	1BH 2DH n	64
12	ESC _	NOP	1BH 5FH n	
13	ESC 4	Specifying the red print	1BH 34H	64
14	ESC 5	Canceling the red print	1BH 35H	64
15	SI	Specifying the inverted character	0FH	65
16	DC2	Canceling the inverted character	12H	65
17	LF	Printing and paper feed	0AH	66
18	CR	Printing	0DH	66
19	ESC z	Setting the 1/6-inch line feed	1BH 7AH	66
20	ESC 0	NOP	1BH 30H	
21	ESC a n	n-line paper feed	1BH 61H n	67
22	FF	Form feed (Change the page)	0CH	67
23	ESC C n	Setting the n-line page length	1BH 43H n	67
24	ESC C <0> n	Setting the n-inch page length	1BH 43H 00H n	68
25	VT	Vertical tab	0BH	68
26	ESC B nk <o>	Setting the vertical tab position	1BH 42H nk 00H	69
27	ESC N n	Setting the lower margin	1BH 4EH n	69
28	ESC O	Canceling the lower margin	1BH 4FH	70
29	ESC l n	Setting the left margin	1BH 6cH n	70
30	ESC Q n	Setting the right margin	1BH 51H n	70
31	HT	Horizontal tab	09H	71
32	ESC D n1 n2	Setting the horizontal tab position	1BH 44H n1 n2	72
33	ESC 1	Setting the 1/9-inch line feed width	1BH 31H	73
34	ESC A n	NOP	1BH 41H n	
35	ESC 2	Setting the 2/9-inch line feed width	1BH 32H	73
36	ESC J n	NOP	1BH 4AH n	
37	ESC K n1 <0>	Specifying the 8-dot standard density bit image	1BH 4BH n1 00H	74
38	ESC L n1 n2	Specifying the 8-dot double density bit image	1BH 4CH n1 n2	75
39	ESC h n	Specifying/Canceling the double height character	1BH 68H n	76
40	ESC & <0> n1 n2	Defining the download character	1BH 26H 00H n1 n2	77
41	ESC % n	Specifying/Canceling the download character set	1BH 25H n	78

	Command	Function	Code	Page
42	ESC BEL n1 n2	Setting the external device drive pulse width	1BH 07H n1 n2	79
43	BEL	Driving command A for drawer-1	07H	79

44	FS	Driving command B for drawer-1	1CH	80
45	SUB	Driving command for drawer-2	1AH	80
46	RS	Buzzer-on	1EH	80
47	CAN	Canceling the print data	18H	81
48	DC3	Setting the deselect mode	13H	81
49	DC1	Setting the Select mode	11H	81
50	ESC U n	Unidirectional/bidirectional print mode selection command	1BH 55H n	82
51	ESC @	Initializing the printer	1BH 40H	82
52	ENQ	Enquiry	05H	83
53	STX	Text start	02H	84
54	ETX	Text end command	03H	84
55	ESC d 0 ESC d <0>	Full cut	1BH 64H 30H 1BH 64H 00H	86
56	ESC d 1 ESC d <1>	Partial cut	1BH 64H 31H 1BH 64H 01H	86
57	ESC t n	Selecting the character code table	1BH 74H n	86
58	ESC /n	Defining the message	1BH 2FH n	87
59	ESC DC3 n	Printing the message	1BH 13H n	87
60	ESC y n	Setting the print lines after paper near end detection	1BH 79H n	88
61	ESC DC2 n1 n2	Deleting the download character, message bit image	1BH 12H n1 n2	88
62	GS DC2 n1 n2	Defining the download bit image	1DH 12AH n1 n2	89
63	GS /m	Printing the download bit image	1DH 2FH m	90

Details

~~ESC "R" n~~

[Function] Selecting the international character set

[Code] <1B>H <52>H n

[Range] 0 n 10

[Outline] This command selects the international characters according to the value of n.

n	Character Set	n	Character Set
0	U.S.A.	6	Italy
1	France	7	Spain
2	Germany	8	Japan
3	U.K.	9	Norway
4	Denmark I	10	Denmark II
5	Sweden		

[Default] Depends upon DIP switch setting.

SO

[Function] Specifying the double width character

[Code] <0E>H

[Outline] The data following this command is printed doubled in the horizontal direction. Double width characters remain valid until the double width character cancel command is entered, but they are also cancelled after they are printed one line. Note that the double width characters take up two ordinary characters worth of width.

~~DC4~~

[Function]	Canceling the double width character
[Code]	<14>H
[Outline]	This command deselects the double width characters set with SO. The data following this command will be printed in ordinary characters.

ESC "E"

[Function]	Specifying the highlight character
[Code]	<1B>H <45>H
[Outline]	The data following this command is printed in highlight (double) characters. The highlight characters remain valid until the highlight character deselection command is entered.

ESC "F"

[Function]	Canceling the highlight character
[Code]	<1B>H <46>H
[Outline]	This command deselects the highlight characters set with ESC "E". The data following this command will be printed in ordinary characters.

ESC "-" n

[Function]	Specifying/Canceling the underline
[Code]	<1B>H <2D>H n
[Outline]	This command selects/deselects an underline. The underline is selected at n = 1 and deselected at n = 0. The space by the horizontal tab is not underlined.

ESC "4"

[Function]	Specifying the red print
[Code]	<1B>H <34>H
[Outline]	This command prints its subsequent data in red. This command remains valid until the red print deselection command is entered. Red and black characters cannot be mixed in one line.

ESC "5"

[Function]	Canceling the red print
[Code]	<1B>H <35>H
[Outline]	This command deselects red print.

~~SI~~

[Function] Specifying the inverted character

[Code] <0F>H

[Outline] This command selects and prints the inverted characters. Enter it at the beginning of one line. Otherwise, it will be invalid. Erect and inverted characters cannot be mixed in one line.

DC2

[Function] Canceling the Inverted character

[Code] <12>H

[Outline] This command deselects the inverted characters. Enter this command at the beginning of one line.

LF

[Function] Printing and paper feed

[Code] <0A>H

[Outline] If the print buffer contains the data, this command will feed the line after printing. If not, the command only feeds the line.

CR

[Function]	Printing and paper feed (Same as LF)
[Code]	<0D>H
[Outline]	The function is the same "LF." However, if the DIP switch segment 1-6 is set to ON, this command is ignored.

~~ESC "z"~~

[Function]	Setting the standard line feed width
[Code]	<1B>H <7A>H
[Outline]	This command sets the line feed width as follows. For character type: 1/6 For graphic type: 2/9 inch

~~ESC "a" n~~

[Function]	Setting the n-line paper feed
[Code]	<1B>H <61>H n
[Range]	1 n 127
[Outline]	This command feeds the paper by the number of lines specified with n. You can set n = 1 to 127 lines. If the print buffer contains the data, use of this command feeds the paper by n-lines after printing the data.

~~FF~~

[Function]	Form feed (Changing the page)
[Code]	<0C>H
[Outline]	This command searches for the head of the next page after printing the data in the print buffer.

ESC "C" n

[Function]	Setting the n-line page length
[Code]	<1B>H <43>H n
[Range]	1 n 255
[Outline]	Sets the 1-page length to n-lines.
[Default]	n = 42

ESC "C" <0> n

[Function]	Setting the n-inch page length
[Code]	<1B>H <43>H <0> n
[Range]	1 n 127
[Outline]	This command sets the length of one page to n-inches.

VT

[Function] Vertical tab

[Code] <0B> H

[Outline] This command feeds the paper to the next vertical tab position. It cannot be fed unless the vertical tab position has been set. If the current position is equal to or greater than the maximum set vertical tab position, it will be fed to the head of the next page.

ESC "B" [n]k NUL

[Function] Setting the vertical tab position

[Code] <1B>H <42>H [n]k <00>H

[Range] 1 n 255
1 k 16

[Outline] This command cancels the already set vertical tab positions and sets new vertical tab positions. They are set in the ascending order and ends with <00>. Up to 16 vertical tabs can be set. If the tab setting position <nk> is equal or smaller than the preceding set position <nk-1>, it is assumed that setting of the vertical tabs has been completed.

ESC "N" n

[Function]	Setting the lower margin
[Code]	<1B>H <4E>H n
[Range]	0 n 255
[Outline]	This command sets the n-line lower margin.
[Default]	n = 0

~~ESC "O"~~

[Function]	Canceling the lower margin
[Code]	<1B>H <4F>H
[Outline]	This command deselects the set lower margin.

ESC "I" n

[Function]	Setting the left margin
[Code]	<1B>H <6C>H n
[Range]	0 n (Right margin - 2)
[Outline]	This command sets the left margin and printing starts from the column next to the set margin.

ESC "Q" n

[Function]	Setting the right margin
[Code]	<1B>H <51>H n
[Range]	2 n (Max. print columns)
[Outline]	This command sets the right margin and printing is performed up to n-columns.

HT

[Function]	Horizontal tab
[Code]	<09>H
[Outline]	This command moves a printing position to the preset next horizontal tab position. This command will be ignored unless there is the next horizontal tab position.

ESC "D" n1 n2 NUL

[Function] Setting the horizontal tab position

[Code] <1B>H <44>H n1 n2 <00>H

[Range] 1 n Max. print columns - 1
 1 k 16

[Outline] This command sets the horizontal tab positions. n indicates the number of lines from the head of the line to the horizontal tab setting position. k indicates the number of horizontal tab positions to be set.

The tab position is set at the character width \times n from the head of the line. The character width at this time includes the right space of the character and will be doubled if the double width characters are specified.

The data <n>k indicating the set position is entered in the ascending order and ends with <00>H. ESC D NUL clears all the set tab positions. After clearing the tab positions, HT will be ignored.

[Caution] If the data <n>k is equal to or smaller than the preceding data <n>k - 1, it is assumed that horizontal tab setting has been completed. In that case, the subsequent data will be processed as regular one.

Up to 16 tab positions can be set. If the data exceeds this limit, it will be processed as regular data. If the data <n>k exceeds the one-line print range, the set column position will equal the maximum print columns + 1.

If the character width is changed after setting the horizontal tab positions, they will not change.

ESC "1"

(Graphic Type)

[Function] Setting the 1/9-inch line feed width

[Code] <1B>H <31>H

[Outline] This command sets the line feed width to 1/9 inch.

ESC "2"

(Graphic Type)

[Function] Setting the 2/9-inch line feed width

[Code] <1B>H <32>H

[Outline] This command sets the line feed width to 2/9 inch.

~~ESC "K" n1 <0> m1 m2 ... (Graphic Type)~~

[Function] Specifying the 8-dot standard density bit image

[Code] <1B>H <4B>H n1 <00>H m1 m2 ...

[Range] 1 n1 180/2 (DP654 mechanism)
1 n1 200/2 (DP657 mechanism)

[Outline] This command prints the bit image by the number of data specified with n1. Printing will be unidirectional. The surplus data exceeding the printable quantity in one line will be ignored. The printer will automatically return to the character mode after printing the bit image.

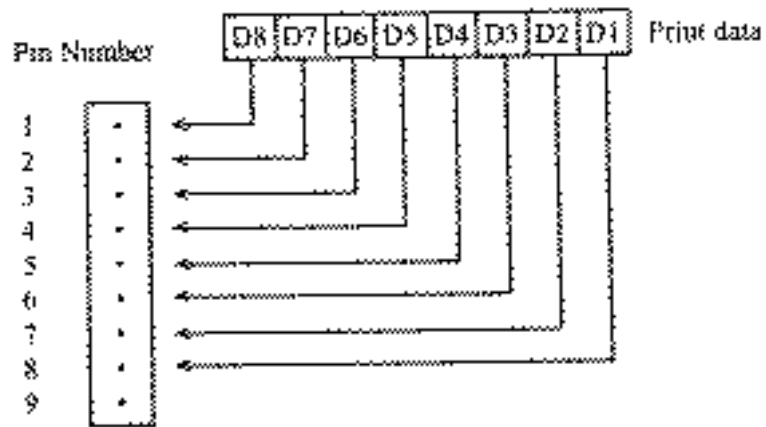

~~ESC "L" n1 n2 m1 m2 ... (Graphic Type)~~

[Function] Specifying the 8-dot double density bit image

[Code] <1B>H <4C>H n1 n2 m1 m2 ...

[Range] 1 n1 + 256 × n2 360 (DP654 mechanism)
1 n1 + 256 × n2 400 (DP657 mechanism)

[Outline] This command prints the 8-dot double density (half-dot print) bit image. Printing will be unidirectional. The surplus data exceeding the printable quantity in one line will be ignored. The printer will automatically return to the character mode after printing the bit image. The relations between the printing head pin numbers and the data are the same as the 8-dot standard density bit image command, <ESC> "K.". When printing the double density bit image, the horizontally adjacent dots cannot be printed.

~~ESC "h" n (Graphic Type)~~

[Function] Specifying/Canceling the double height character

[Code] <1B>H <68>H n

[Outline] The data following this command is printed in double height characters, except the bit image mode <ESC> "K" and <ESC> "L". In combination with the <SO> command, this command can print double height, double width characters. It cannot be combined with the inverted character command, <SI>. The double height characters and ordinary characters shall be bottom-justified.

n	Double height character command
0	Deselects
30	
1	Selects
31	

ESC "&"<O> n1 n2 [m0 m1 m2 m3 m4 m5 m6 m7 m8 m9] n2 - n1 + 1

[Function] Defining the download character set

[Code] <1B>H <26>H <00>H n1 n2 [m0 m1 ... m5 m6 m7 m8 m9] n2 - n1 + 1

[Range] 32 n1 n2 255, m0 = 0 or m0 = 128

[Outline] This command defines the download characters. n1 is a character code to start definition and n2 is to end definition, respectively. When defining only one character, set n1 = n2. You can define the ASCII codes ranging from 32 to 255.
 The horizontally adjacent dots cannot be printed. Once the download bit image is defined, it remains valid until it is redefined or the download deletion command(ESC DC2 n1 n2) is executed.

When m0={80}H

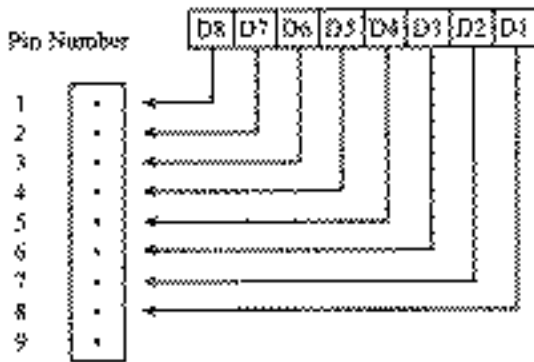

When m0={00}H

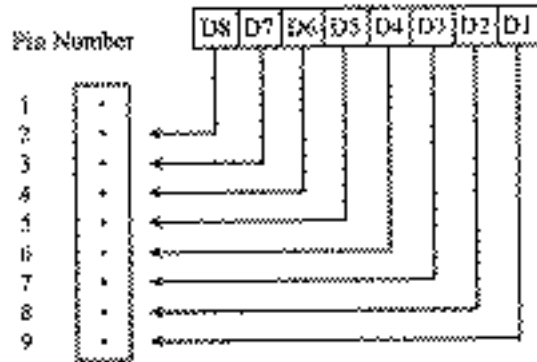

~~ESC "% " n~~

[Function] Specifying/Canceling the download character set

[Code] <IB>H <25>H n

[Outline] This command selects/deselects the download character set. The download characters cannot be printed by simply defining them with the above-mentioned ESC & 0 command. To print them, send this command to the printer.

n	Download Character Set
0	Deselects
30	
1	Selects
31	

~~ESC BEL n1 n2~~

[Function] Setting the external device drive pulse width

[Code] <1B>H <07>H n1 n2

[Range] 1 n1 127
1 n2 127

[Outline] This command sets the power-on time to drive an external device(cash drawer).
Power-on time = $n1 \times 10$ (ms)
Delay time = $n2 \times 10$ (ms)
To actually drive the drawer, use the <BEL> and <FS> commands.

~~n1=n2=20~~

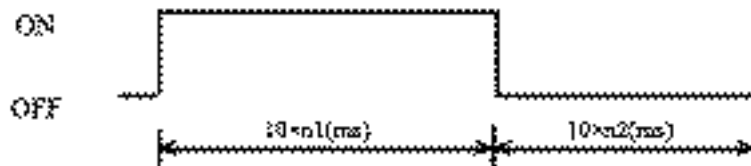

[Default]

BEL

[Function] Driving command A for drawer-1

[Code] <07>H

[Outline] This command drives the drawer connector no. 2 pin under the condition set with the <ESC><BEL> n1 n2 command. This command is executed in order of entry into the input buffer.

FS

[Function]	Driving command B for drawer-1
[Code]	<1C>H
[Outline]	This command drives the drawer connector no. 2 pin under the condition set with the <ESC><BEL> n1 n2 command.

SUB

[Function]	Driving command for drawer-2
[Code]	<1A>H
[Outline]	As soon as this command is received, the drawer connector no. 5 pin is driven. The power-on time is 200 ms ON and 200 ms OFF stationary. The drawers 1 and 2 cannot be driven simultaneously.

RS

[Function]	Buzzer-on
[Code]	<1E>H
[Outline]	This command emits a short warning sound from the printer.

CAN

[Function]	Canceling the print data
[Code]	<18>H
[Outline]	This command clears the input buffer and print buffer. In the STX-EXT mode of the serial interface printer, the command clears the data in the data buffer and ends the STX-ETX mode.

DC3

[Function]	Setting the deselect mode
[Code]	<13>H
[Outline]	If the printer receives <DC3>, it will ignore the subsequent data. The Deselect mode is cancelled by <DC1>.

DC1

[Function]	Setting the select mode
[Code]	<11H>
[Outline]	If the printer receives this command, it will save the subsequent data in the input buffer.

ESC "U" n

[Function] Selecting the Unidirectional/Bidirectional print mode

[Code] <1B>H <55>H n

[Range] 0 n 255

[Outline] This command selects or deselects unidirectional print.

n0 = 0	Bidirectional print
n0 = 1	Unidirectional print

ESC "@"

[Function] Initializing the printer

[Code] <1B>H <40>H

[Outline] This command cancels various conditions set after power-on to initializes the printer to the conditions having existed at power-on. However, the input buffer is not initialized.

ENQ

[Function]	Enquiry
[Code]	<05>H
[Outline]	This command is valid only for the serial interface. The printer sends the status information. If this command is entered after receiving the text information in the STX-ETX mode, the printer will send the status information and check byte.

Status

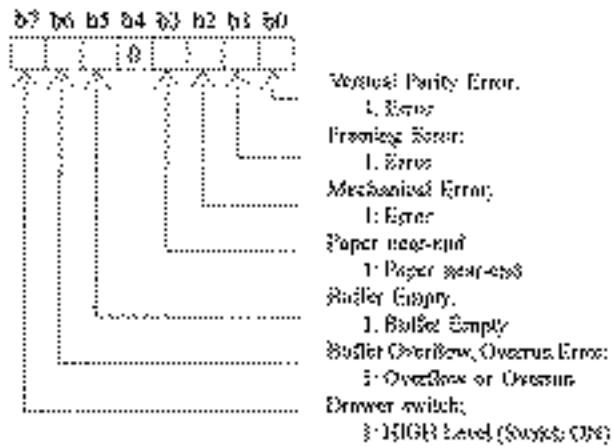

STX

[Function]	
[Code]	<02>H
[Outline]	This command is valid only for the serial interface. It effectuates the STX-ETX mode.

ETX

[Function]	Text end
[Code]	<03>H
[Outline]	This command is valid only for the serial interface. It ends the STX-ETX mode and prints the data.

***ETX-STX Mode**

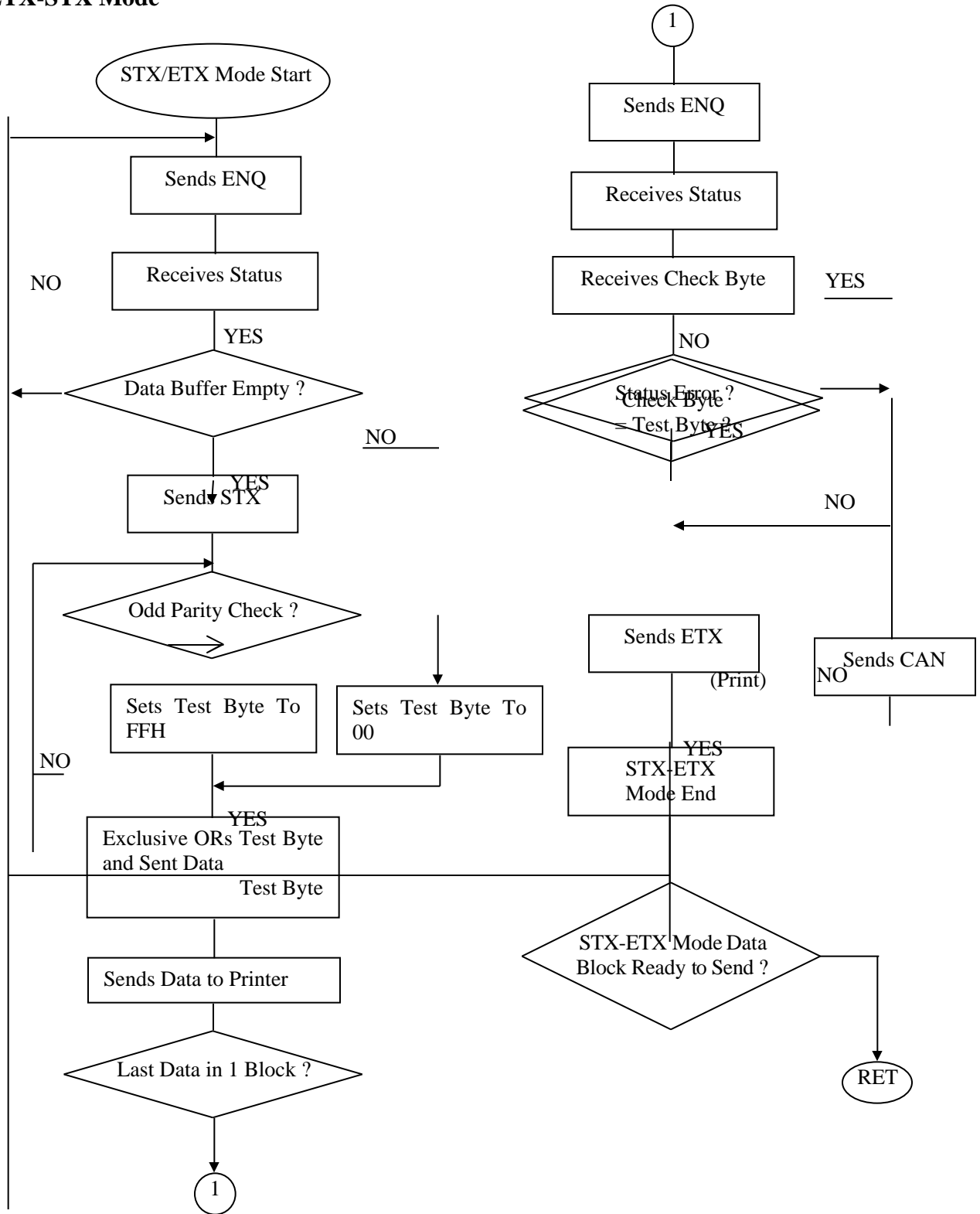

~~ESC "d" "0" or ESC "d" <0> (iDP-3551 Only)~~

[Function] Full cut
[Code] <1B>H<64>H<30>H or <1B>H<64>H<00>H
[Outline] This command fully cuts the paper.

ESC "d" "1" or ESC "d" <1> (iDP-3551 Only)

[Function] Partial cut
[Code] <1B>H<64>H<31>H or <1B>H<64>H<01>H
[Outline] This command partially cuts the paper.

ESC "t" n

[Function] Selecting the character code table
[Code] <1B>H <74>H n
[Range] 0 n 255
[Outline] This command selects Page-n of Character Code Table.
[Default] Depends on DIP switch setting.

n	Character Code Table	n	Character Code Table
0	STAR International	6	Code Page 852 (Eastern Europe)
1	STAR Domestic	7	Code Page 866 (Russia)
2	Code Page 850 (Multilingual)	8	Code Page 857 (Turkey)
3	Code Page 860 (Portugal)	9	Windows Code
4	Code Page 863 (Canada-French)		
5	Code Page 865 (Norway)	255	Space Page (For user setting)

~~ESC "/" n "data" CR or LF~~

[Function]	Defining the message
[Code]	<1B>H <2F>H n "data" CR or LF
[Range]	1 n 10
[Outline]	<p>This command can define up to a 50-byte message in one line. If the value of n is specified beyond the range, the data following n will be treated as the print data.</p> <p>Once the message is defined, it remains valid until it is redefined. The data should end with CR (0DH) or LF (0AH). If the data exceeds 50 bytes, the subsequent data will be treated as the print data.</p> <p>Once the message is defined, it remains valid until it is redefined or the download deletion command (ESC DC2 n1 n2) is executed.</p>

~~ESC "DC3" n~~

[Function]	Printing the message
[Code]	<1B>H <13>H n
[Range]	1 n 10
[Function]	<p>This command prints a message. If the value of n is specified beyond the range or if nothing is specified to n, the message will not be printed.</p>

ESC "y" n

[Function]	Setting the print lines after paper near end detection
[Code]	<1B>H<79>H n
[Range]	0 n1 255
[Outline]	This command sets the number of print lines after paper near end detection. It stops printing after printing $n \times 2$ lines since detection of the paper near end, resulting in the paper near end state (See 4.11 Operation Panel and Display of Error). The PE signal (parallel interface only) changes when the paper near end is detected.
[Default]	$n = 0$

ESC DC2 n1 n2

[Function]	Deleting the download character, message, bit image
[Code]	<1B>H <12>H n1 n2
[Range]	0 n1 3 0 n2 (Specify 0 at $n1 = 0$) (1 n2 10 at $n1 = 1$) (32 n2 224 at $n1 = 2$) (Specify 0 at $n1 = 3$)
[Outline]	This command deletes the downloaded characters, message, and bit image.

n1	Object Deleted
0	All(Message, characters, bit image)
1	Download message
2	Download characters
3	Download bit image

With $n2$, specify which data of the function specified with $n1$ should be deleted.

$n2 = 0$	Deletes all the download function specified with $n1$.
$n2 \neq 0$	Deletes the data downloaded at the value specified with $n2$ (value specified when saving with each download command), of the download function specified with $n1$.

GS "*" n1 n2 [d] n1 × n2 × 8

[Function] Defining the download, bit image

[Code] <1D>H <2A>H <n1> <n2> [<d>] n1 × n2 × 8

[Range] 1 n1 45 0 n2 24

Note) Take care that the number of data(n1×n2×8) is equal to or smaller than 2,048.

[Outline] This command defines the download bit image having the dots specified n1 and n2. The number of horizontal dots is represented by n1 × 8 and that of vertical dots is represented by n2 × 8, respectively. d denotes the number to be registered. (See a download bit image printout.) d denotes the bit image data. Once the download bit image is defined, it remains valid until it is redefined or the download deletion command(ESC DC2 n1 n2) is executed.

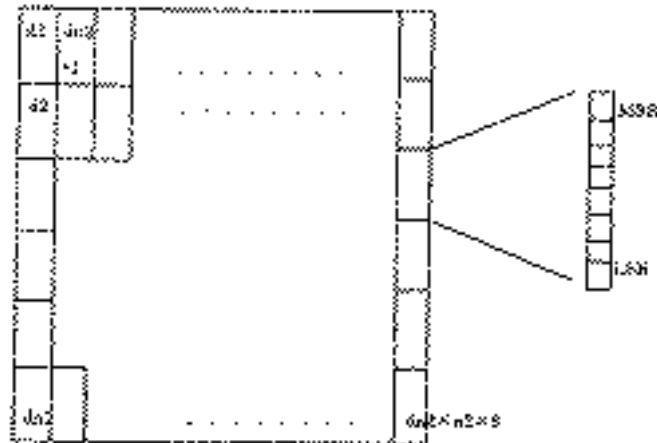

~~GS/m~~

~~(Graphic Type)~~

[Function] Printing the download bit image

[Code] <1D>H <2F>H m

[Range] 0 m 255

[Outline] This command prints the bit image saved in the number specified with m.

[Caution] If the print buffer contains the data, this command will be ignored. If the bit image has not been saved in the specified number, this command will be ignored.
Nothing is printed when m is other than 0,1,2 or 3.

14.3 ESC/POS Commands

14.3.1 Command List

	Command	Function	Code	Page
1	HT	Horizontal tab	09H	92
2	LF	Printing and paper feed	0AH	92
3	CR	Printing	0DH	93
4	ESC (Space) n	Setting thr character right space	1BH 20H n	93
5	ESC ! n	Setting print mode batch	1BH 21H n	94
6	ESC % n	Specifying/Canceling the download character set	1BH 25H n	95
7	ESC & s n m [a[p] s × a]	Defining the download character set	1BH 26H s n m [a[p]s×a] m-n+1	96
8	ESC m n1 n2 [d] n1 + 256 × n2	Specifying the bit image mode	1BH 2AH m n1 n2 [d] n1 + 256×n2	97
9	ESC 2	Setting the 1/6-inch line feed rate	1BH 32H	98
10	ESC 3 n	Setting the line feed width in minimum pitch increments	1BH 33H n	98
11	ESC <	NOP	1BH 3CH	
12	ESC @	Initializing the printer	1BH 40H	98
13	ESC D [n] k NUL	Setting the Horizontal tab position	1BH 44H [n] k 00H	99
14	ESC J n	NOP	1BH 4AH n	
15	ESC R n	Selecting the international character set	1BH 52H n	100
16	ESC U n	Specifying/Canceling the unidirectional print mode	1BH 55H n	101
17	ESC c 0 n	NOP	1BH 63H 30H n	
18	ESC c 4 n	Selecting the paper near end sensor valid for print stop	1BH 63H 34H n	102
19	ESC c 5 n	Selecting the panel switch enable/disable	1BH 63H 35H n	102
20	ESC d n	Printing and n-line paper feed	1BH 64H n	103
21	ESC I	Full cut	1BH 69H	103
22	ESC m	Partial cut	1BH 6DH	103
23	ESC p m n1 n2	Specifying the pulse generation	1BH 70H m n1 n2	104
24	ESC r n	Selecting the printing color	1BH 72H n	105
25	ESC t n	Selecting the character code table	1BH 74H n	105
26	ESC u n	Sending the status for peripheral device	1BH 75H n	106
27	ESC v	Sending the printer status	1BH 76H	107
28	ESC { n	Specifying/Canceling the inverted character print	1BH 7BH n	108
29	GS E n	NOP	1DH 45H n	
30	ESC /n	Defining the message	1BH 2FH n	108
31	ESC DC3 n	Printing the message	1BH 13H n	109
32	ESC y n	Setting the print lines after paper near end detection	1BH 79H n	109
33	ESC DC2 n1 n2	Deleting the download character, message, bit image	1BH 12H n1 n2	110
34	GS n1 n2	Defining the download bit image	1DH 2AH n1 n2	111
35	GS /m	Printing the download bit image	1DH 2FH m	112

Details

HT

[Function]	Horizontal tab
[Code]	<09>H
[Outline]	This command moves a printing position to the next horizontal tab position. If the next horizontal tab position is not set, this command will be ignored.
[Caution]	The horizontal tab position is set by <ESC> D. Initial setting of the horizontal tab position is every 8 characters (9th, 17th, 25th columns, and so on).

LF

[Function]	Printing and paper feed
[Code]	<0A>H
[Outline]	This command prints one line worth of the data saved in the print buffer and feeds the line based on the set line feed value. The head of the line is assumed to be the next print start position.

CR

[Function]	Printing
[Code]	<0D>H
[Outline]	This command prints the data. If the DIP switch segment 1-6 is set to OFF, the printer will print the data in the print buffer and feed the paper by one line. If it is set to ON, the printer will print the data in the print buffer and will not feed the paper.

~~ESC " " n~~

[Function]	Setting the character right space
[Code]	<1B>H <20>H n
[Range]	0 n 32
[Outline]	This command sets the right space of the character.
[Caution]	In the double width mode, the right space will be double the set amount. Set the space in increments of half dot.
[Default]	n = 0

~~ESC "!" n~~

[Function] Setting the print mode batch

[Code] <1B>H <21>H n

[Range] 0 n 255

[Outline] Sets the print mode. "n" (Each bit) has the following meanings.

Bit	Function	Values	
		0	1
0	Undefined	-	-
1	Undefined	-	-
2	Undefined	-	-
3	High-lighting	Canceled	Specified
4	Double height	Canceled	Specified (Graphic Type)
5	Double width	Canceled	Specified
6	Undefined	-	-
7	Underline	Canceled	Specified

[Caution] The entire character print width is underlined, but the portion skipped by HT is not. If both double height and double width are selected, the characters will be quadrupled. If the double width characters are selected, some dots may not be printed depending on the preceding one. Double height is selectable only for graphic type.

[Default] n = 0

~~ESC "% " n~~

[Function]	Specifying/Canceling the download character set
[Code]	<1B>H <25>H n
[Range]	0 n 255
[Outline]	This command selects/deselects the download character set. n is valid only for the least significant bit. Setting n0 = 1 selects the download character set. Setting n0 = 0 deselects the download character set.
[Default]	n = 0

ESC "&" s n m [a[p] s × a]m - n + 1

[Function] Defining the download character set

[Code] <1B>H <26>H s n m [a[p] ... <ps × a>] m - n + 1

[Range] s = 2
 32 n m 255
 0 a 9
 0 p1 ... ps × a 255

[Outline] This command defines the download alphanumeric or Katakana. s denotes the number of bytes in the vertical direction, n the start character code, and m the end character code, respectively. When defining only one character, set n = m.
 The 224 ASCII code characters, 32 to 255, are definable. a specifies the number of dots in the horizontal direction to be defined. p is the data you want to define and shows the a-dots worth of pattern in the horizontal direction from the left edge. The remaining pattern on the right side will be a space. Once the download characters are defined, they remain valid until they are redefined or the download deletion command (ESC DC2 n1 n2) is executed.

[Default] Same as the internal character set.

[Caution] The horizontally adjacent dots cannot be printed. The 2nd-byte data in the vertical direction is valid only for the most significant bit.

Example

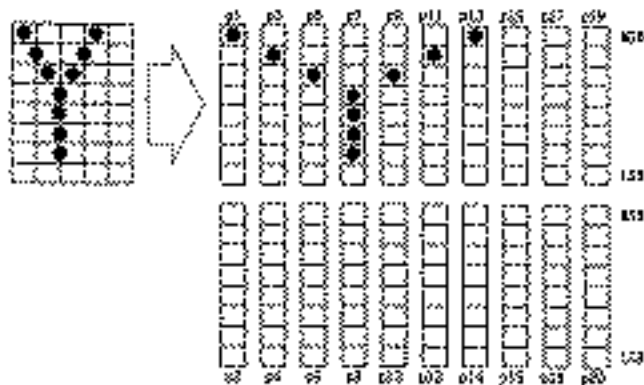

ESC "*" m n1 n2 [d] n1 + 256 × n2 (Graphic Type)

[Function] Specifying the bit image mode

[Code] <1B>H <2A>H m n1 n2 [d] n1 + 256×2

[Range] m = 0, 1
 0 n1 255
 0 n2 3
 0 d 255

[Outline] This command specifies the bit image for the mode m as to the number of dots specified with n1 and n2. Divide the number of dots printed by 256 and assume its quotient to be n2 and remainder to be n1. Therefore, the number of horizontal dots will be n1 + 256 × n2. If the bit image data is entered beyond the dot positions printable in one line, the surplus data will be discarded. The following table shows the bit image modes for m.

m	Vertical Dots	Horizontal Direction			
		Dot Density	Adjacent Dot Setting	Total Dots	
				DP654	DP657
0	8	Single density	Allowed	180	200
1	8	Double density	Disallowed	360	400

[Caution] If the value of m is beyond the conditions, the data subsequent to n1 will be processed as normal data. Normal data processing will be restored after completing bit image print.

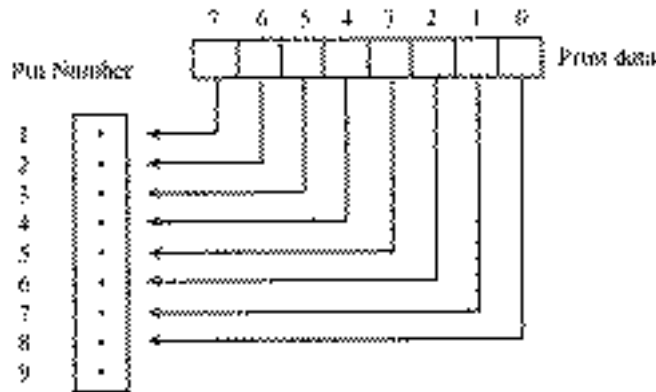

~~ESC "2" (Character Type)~~

- [Function] Setting the standard line feed width
- [Code] <1B>H <32>H
- [Outline] This command sets the following line feed width.
For character type: 1/6 inch.
For graphic type: 2/9 inch

ESC "3" n (Graphic Type)

-
- [Function] Setting the line feed width in minimum pitch increments
 - [Code] <1B>H <33>H n
 - [Outline] This command is only effective for graphic type. This command sets the line feed width to n/9 inch.
 - [Default] n = 2

ESC "@"

-
- [Function] Initializing the printer
 - [Code] <1B>H <40>H
 - [Outline] This command cancels various conditions set after power-on to initializes the printer to the conditions having existed at power-on. However, the print buffer, input buffer, and external device drive pulse width are not initialized. The settings of the DIP switch segments are not re-read.

ESC "D" [n]k NUL

[Function]	Setting the Horizontal tab position
[Code]	<1B>H <44>H [n]k <00>H
[Range]	1 n 255 0 k 32
[Outline]	<p>This command sets the horizontal tab position. n denotes the number of columns from the head of the line to the horizontal tab setting. k denotes the number of horizontal tab positions to be set. The tab position is set at the character width \times n from the head of the line. The character width at this time includes the space to the right of the character; it will be double the normal character width if the double width characters are selected.</p> <p>The data <n>k denoting the set position is entered in the ascending order and ends with <00>H. ESC D NUL clears all the set tab positions. HT is ignored after clearing.</p>
[Caution]	<p>If the data <n>k is equal to or smaller than the preceding data <n>k - 1, it is assumed that horizontal tab setting has been completed. If this is the case, the subsequent data will be processed as normal data.</p> <p>Up to 16 horizontal tabs can be set. The data beyond this limit are processed as normal ones. If the data <n>k exceeds the one-line print range, set the "set column position = maximum print columns + 1."</p> <p>Even if the character width is changed after setting the horizontal tab position, the latter will not change.</p>
[Default]	Every 8 characters (9th, 17th, 25th column, and so on)

ESC "R" n

[Function] Selecting the international character set

[Code] <1B>H <52>H n

[Range] 0 n 10

[Outline] This command selects the international characters according to the value of n.

n	Character Set	n	Character Set
0	U.S.A.	6	Italy
1	France	7	Spain
2	Germany	8	Japan
3	U.K.	9	Norway
4	Denmark I	10	Denmark II
5	Sweden		

[Default] Depends upon DIP switch setting.

~~ESC "U" n~~

[Function] Specifying/Canceling the Unidirectional print mode

[Code] <1B>H <55>H n

[Range] 0 n 255

[Outline] This command selects/deselects unidirectional print. n is valid only for the least significant bit.

n	Function
0	Deselects
1	Selects

[Caution] If unidirectional print is selected, the printer will print from the left to the right. When you want to prevent horizontal shear in printing at high accuracy, specify unidirectional print with this command. (For double height print, etc.)

~~ESC "c" "4" n~~

[Function] Selecting the paper near end sensor valid for print stop

[Code] <1B>H<63>H<34>H n

[Range] 0 n 255

[Outline] This command selects the no-paper detector state in which printing should be stopped.

Bit	Function	Value	
		0	1
0	Paper near end	Disabled	Enabled
1	Undefined	-	-
2	Undefined	-	-
3	Undefined	-	-
4	Undefined	-	-
5	Undefined	-	-
6	Undefined	-	-
7	Undefined	-	-

[Default] n = 0

~~ESC "c" "5" n~~

[Function] Selecting the panel switch enable/disable

[Code] <1B>H <63>H <35>H n

[Range] 0 n 255

[Outline] This command enables/disables the panel switches. n is valid only for the least significant bit.

Setting n = 1 disables the panel switches.

Setting n = 0 enables the panel switches.

[Caution] If the panel switches are disabled with this command, the LF switch will be disabled. Therefore, the paper cannot be fed by the LF switch.

[Default] n = 0

ESC "d" n

[Function] Printing and n-line paper feed

[Code] <1B>H <64>H n

[Range] 0 n 255

[Outline] This command feeds the paper by n-lines after printing the one line worth of data saved in the print buffer.

ESC i

(iDP3551 Only)

[Function]	Full cut
[Code]	<1B>H<69>H
[Outline]	This command fully cuts the paper.

ESC m

(iDP3551 Only)

[Function]	Partial cut
[Code]	<1B>H<6D>H
[Outline]	This command partially cuts the paper.

~~ESC "p" m n1 n2~~

[Function] Specifying the pulse generation

[Code] <1B>H <70>H m n1 n2

[Range] 0 m 1
0 n1 n2 255

[Outline] This command outputs the signals specified with n1 and n2 to the connector pins.

m	Connector Pin
0	Drawer kick connector No. 2 pin
1	Drawer kick connector No. 5 pin

The ON time is $n1 \times 2$ mS and the OFF time is $n2 \times 2$ mS.

[Caution] The user should consider driving the drawer at the following duty ratio.

ON time \div (ON time + OFF time) 0.2

(It is recommended to make n2 four times higher or more than n1.)

The drawer kick-out solenoid should have a resistance value of 36 Ω or more. Do not use a lower one because an overcurrent will flow. For the drawer power, be sure to use the printer power (Drawer kick-out connector No. 4 pin).

~~ESC "r" n~~

[Function] Selecting the printing color

[Code] <1B>H <72>H n

[Range] n = 0, 1

[Outline] This command selects a print color for each line. Setting n = 0 selects black. Setting n = 1 selects red. The command is valid only when it is entered at the head of the line.

[Default] n = 0 (Black print)

ESC "t" n

[Function] Selecting the character code table

[Code] <1B>H <74>H n

[Range] 0 n 255

[Outline] This command selects Page-n of Character Code Table.

[Default] Depends on DIP switch setting.

n	Character Code Table	N	Character Code Table
0	Code Page 437 (U.S.A.)	6	Code Page 852 (Eastern Europe)
1	Katakana	7	Code Page 866 (Russia)
2	Code Page 850 (Multilingual)	8	Code Page 857 (Turkey)
3	Code Page 860 (Portugal)	9	Windows Code
4	Code Page 863 (Canada-French)		
5	Code Page 865 (Norway)	255	Space Page (For user setting)

~~ESC "u" n~~

[Function] Sending the status for peripheral device

[Code] <1B>H <75>H n

[Range] n = 0

[Outline] This commands sends the status of the connector No. 3 pin.

n	Connector Pin
0	Drawer kick-out connector No. 3 pin

Status Sent

Bit	Function	Value	
		0	1
0	No. 3 pin's level	"LOW"	"HIGH"
1	Undefined		
2	Undefined		
3	Undefined		
4	Undefined		
5	Undefined		
6	Undefined		

[Caution] This command is valid only for the serial interface. If nothing is connected to the connector, the bit 0 will be always "1". In case of DTR/DSR control, if the host cannot receive (DSR signal has the Mark status), the printer will wait until it will be ready to receive. In case of XON/XOFF control, only one byte will be sent without confirming the status of the DSR signal. Note that it may take time to send the status after receiving the command.

ESC "v"

[Function] Sending the printer status

[Code] <1B>H <76>H

[Outline] This command sends the printer status.

[Caution] This command is valid only for the serial interface. The following table lists the status sent. In case of DTR/DSR control, only one byte will be sent after confirming that the host is ready to receive (DSR signal has the Space status).
The status at command processing time is sent after processing the data received prior to this command. If the printing is under way when the command is being processed, however, the then status will be sent after completing print feed of that line. Therefore, it may take time to send the status after receiving the command.

Bit	Function	Value	
		0	1
0	Paper near end	With paper	Near end
1	Undefined		
2	Paper near end	With paper	End
3	Undefined		
4	Undefined	0 stationary	-
5	Undefined		
6	Undefined		

~~ESC "{ " n~~

[Function] Specifying/Canceling the inverted character print

[Code] <1B>H <7B>H n

[Range] 0 n 255

[Outline] This command selects/deselects inverted print. n is valid only for the least significant bit.

n	Type
0	Deselects the inverted characters.
1	Selects the inverted characters.

[Caution] This command is valid only if entered at the head of the line.

[Default] n = 0

<Example>

When Inverted Print Is
Deselected

When Inverted Print Is
Selected

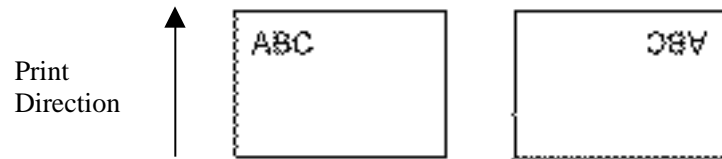

ESC "/" n "data" CR or LF

[Function] Defining the message

[Code] <1B>H <2F>H n "data" CR or LF

[Range] 1 n 10

[Outline] This command defines up to a 50-byte message in one line. If the value of n is specified beyond the range, the data following n will be treated as the print data.

Once the message is defined, it remains valid until it is redefined. The data should end with CR (0DH) or LF (0AH). If the data exceeds 50 bytes, the subsequent data will be treated as the print data.

Once the message is defined, it remains valid until it is redefined or the download deletion command (ESC DC2 n1 n2) is executed.

~~ESC DC3 n~~

[Function] Printing the message

[Code] <1B>H <13>H n

[Range] 1 n 10

[Function] This command prints a message. If the value of n is specified beyond the range, or if the message is not registered yet the message will not be printed.

ESC "y" n

[Function] Setting the print lines after paper near end detection

[Code] <1B>H<79>H n

[Range] 0 n 255

[Outline] This command sets the number of print lines after paper near end detection. It stops printing after printing $n \times 2$ lines since detection of the paper near end, resulting in the paper near end state (See 4.11 Operation Panel and Display of Error). The PE signal (parallel interface only) changes when the paper near end is detected.

[Caution] This command is only valid if the paper near end is selected with ESC c4 n, the command to select the paper near end sensor valid for print stop.

[Default] n = 0

~~ESC DC2 n1 n2~~

[Function] Deleting the download character, message, bit image

[Code] <1B>H <12>H n1 n2

[Range] 0 n1 3
0 n2 (Specify 0 at n1 = 0)
(1 n2 10 at n1 = 1)
(32 n2 224 at n1 = 2)
(Specify 0 at n1 = 3)

[Outline] This command deletes the downloaded characters, message, and bit image.

n1	Object Deleted
0	All(Message, characters, bit image)
1	Download message
2	Download characters
3	Download bit image

With n2, specify which data of the function specified with n1 should be deleted.

n2 = 0 Deletes all the download function specified with n1.

n2 0 Deletes the data downloaded at the value specified with n2 (Value specified when saving with each download command), of the download function specified with n1.

~~GS "*" n1 n2 [d] n1 × n2 × 8~~

(Graphic Type)

[Function] Defining the download bit image

[Code] <1D>H <2A>H <n1> <n2> [<d>] n1 × n2 × 8

[Range] 1 n1 45
0 n2 24

Note) Take care that the number of data(n1×n2×8) is equal to or smaller than 2,048.

[Outline] This command defines the download bit image having the dots specified n1 and n2. The number of horizontal dots is represented by n1×8 and that of vertical dots is represented by n2×8, respectively. d denotes the number to be registered. (See a download bit image printout.) d denotes the bit image data. Once the download bit image is defined, it remains valid until it is redefined or the download deletion command (ESC DC2 n1 n2) is executed.

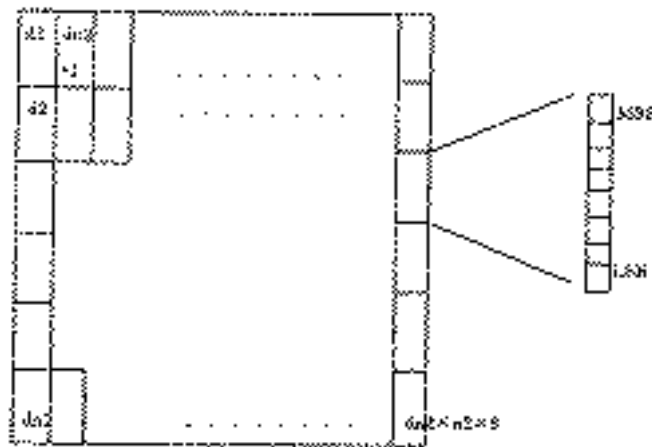

~~GS/m~~

~~(Graphic Type)~~

[Function] Printing the download bit image

[Code] <1D>H <2F>H m

[Range] 0 m 255

[Outline] This command prints the bit image saved in the number specified with m.

[Caution] If the print buffer contains the data, this command will be ignored. If the bit image has not been saved in the specified number, this command will be ignored.
Nothing is printed when m is other than 0, 1, 2 or 3.

15. CHARACTER CODES TABLE

15.1 CBM (Domestic)

	0	1	2	3	4	5	6	7	8	9	A	B	C	D	E	F
0	NUL		SP	0	@	P	'	p			SP	-	タ	ミ	円	σ
1		DC1	!	1	A	Q	a	q			.	ア	チ	ム	日	×
2		DC2	"	2	B	R	b	r			「	イ	ツ	メ	月	ε
3		DC3	#	3	C	S	c	s			」	ウ	テ	モ	年	×
4			\$	4	D	T	d	t			,	エ	ト	ヤ	↓	∞
5			%	5	E	U	e	u			•	オ	ナ	ユ	≠	±
6			&	6	F	V	f	v			ヲ	カ	ニ	ヨ	θ	÷
7	BEL		'	7	G	W	g	w			〒	キ	ヌ	ラ	λ	π
8		CAN	(8	H	X	h	x			イ	ク	ネ	リ	φ	
9)	9	I	Y	i	y			†	ケ	ノ	ル	〒	
A	LF		*	:	J	Z	j	z			エ	コ	ハ	レ	£	
B		ESC	+	:	K	[k	{			†	サ	ヒ	ロ	℃	
C	FF		,	<	L	¥	l				†	シ	フ	ワ	'F	
D	CR		-	=	M]	m	}			エ	ス	ヘ	ン	Ω	
E	SO		.	>	N	^	n	~			†	セ	ホ	'	μ	
F	SI		/	?	O	_	o	■			†	ソ	マ	'	Σ	

15.2 CBM (International)

	0	1	2	3	4	5	6	7	8	9	A	B	C	D	E	F
0	ML		SP	0	@	P	'	p			£	U	e	ù		
1		001	!	1	A	Q	a	q			¢	B	è	é		
2		002	^	2	B	R	b	r			ƒ	S	í	ì		
3		003	#	3	C	S	c	s			ƒ	a	î	ñ		
4			\$	4	D	T	d	t			µ	o	ï	ß		
5			%	5	E	U	e	u			£	·	ï	È		
6			&	6	F	V	f	v			o	TL	ì	Ö		
7	BEL		'	7	G	W	g	w			×	½	ó	í		
8		CAN	(8	H	X	h	x			e	W	ó	À		
9)	9	I	Y	i	y			×	Ï	ò	é		
A	LF		*	:	J	Z	j	z			∞	Y	ó	Œ		
B		ESC		:	K	[k	[±	K	ó	ä		
C	FF		<	<	L	\	l				+	À	ü	ä		
D	CR		~	=	M]	m]			π	a	ü	ä		
E	SO		.	>	N	-	n	~			À	é	ü	ä		
F	SI		/	?	O		o	■			Ö	ó	ü	ä		

15.3 STAR (Domestic)

	0	1	2	3	4	5	6	7	8	9	A	B	C	D	E	F
0	NUM		SP	0	@	P	'	p	SP	!	SP	---	タ	ミ		+
1		OG	!	1	A	Q	a	q		r	*	ア	チ	△	---	---
2	STX	OG	"	2	B	R	b	r	---	■	。	イ	ツ	メ	---	---
3	ETX	OG	#	3	C	S	c	s		■	。	ウ	テ	モ		---
4		OD	\$	4	D	T	d	t	---	■	。	エ	ト	ヤ	+	
5	END		%	5	E	U	e	u		■	。	オ	ナ	ユ	。	
6			&	6	F	V	f	v	---	/	マ	カ	ニ	ヨ	。	
7	BEL		'	7	G	W	g	w		\	フ	キ	ヌ	ラ	。	■
8		OM	(8	H	X	h	x	---	▼	イ	ク	ネ	リ	■	■
9	HT)	9	I	Y	i	y		▼	ウ	ケ	ノ	ル	■	▲
A	LF	MM	*	:	J	Z	j	z	---	↑	エ	ソ	ハ	レ	。	▲
B	VT	SS	+	:	K	[k	[↑	フ	サ	ヒ	ロ	。	#
C	FF	FS	,	<	L	¥	l	¥	↑	↑	ヤ	シ	フ	ワ		■
D	CR	GS	---	=	M]	m]	---	↑	ユ	ス	ヘ	ン	---	▲
E	SO	RS	.	>	N	^	n	~	↓	◆	ウ	セ	ホ	。		▲
F	SI		/	?	O	_	o	■	↑	×	ケ	ソ	マ	。	▲	▲

15.4 STAR (International)

	0	1	2	3	4	5	6	7	8	9	A	B	C	D	E	F
0	NL		SP	0	⊙	P	'	p	SP	⌋	À	Á	Â	Ã	Ä	Å
1		DOJ	!	1	A	Q	a	q	⌋	Œ	é	ù	â	—	—	—
2	STX	DOJ	°	2	B	R	b	r	—	■	Û	e	â	^	—	—
3	ETX	DOJ	#	3	C	S	c	s	⌋	■	Ü	e	ç	Û	⌋	—
4		DO4	\$	4	D	T	d	t	—	■	Ý	ÿ	ÿ	Û	⌋	⌋
5	ENQ		%	5	E	U	e	u	⌋	■	à	ï	Ŕ	Ŕ	⌋	⌋
6			&	6	F	V	f	v	—	/	ò	ì	ŕ	ŕ	⌋	⌋
7	BEL		'	7	G	W	g	w	⌋	/	é	ì	È	È	⌋	⌋
8		DOX	(8	M	X	m	x	—	▼	è	ì	Ò	ò	■	■
9	HT)	9	I	Y	i	y	⌋	▼	é	ó	ì	×	■	■
A	LF	STX	*	:	J	Z	j	z	—	⌋	ŷ	ó	À	È	⌋	■
B	VT	ESC	+	:	K	[k	[⌋	⌋	ï	ó	ó	×	⌋	⌋
C	PY	FS	.	<	L	\	l	\	⌋	⌋	ŷ	ó	ò	∞	⌋	■
D	CR	GS	--	=	M]	m]	—	⌋	ÿ	ó	á	∞	→	⌋
E	SG	RS	.	>	N	^	n	~	⌋	◆	À	ù	á	∞	⌋	⌋
F	SI		/	?	O	_	o	■	⌋	×	é	ó	á	κ	'	>

15.5 Code Page 437

128	144	160	176	192	208	224	240
8-	9-	A-	B-	C-	D-	E-	F-
Ç	É	İ	İ	Ł	Œ	α	π
ü	æ	ı	ı	ł	œ	β	ϕ
ø	Æ	ö	ı	Ł	Œ	Γ	ϙ
â	â	â	ı	ı	Œ	η	ϖ
â	â	â	ı	ı	Œ	ξ	ϗ
â	â	â	ı	ı	Œ	ο	Ϙ
â	â	â	ı	ı	Œ	π	ϙ
ç	é	ı	ı	ł	œ	τ	ς
è	ÿ	ı	ı	Ł	Œ	Φ	ο
é	Û	ı	ı	Ł	Œ	Θ	ϑ
é	Û	ı	ı	Ł	Œ	Γ	ϖ
ı	ε	¼	ı	ı	ı	δ	√
ı	£	¼	ı	ı	ı	∞	"
ı	¥	ı	ı	ı	ı	φ	²
À	Œ	ı	ı	ı	ı	ç	ı
Á	ı	ı	ı	ı	ı	ı	ı

15.6 Katakana

	0	1	2	3	4	5	6	7	8	9	A	B	C	D	E	F
0	NR		SP	0	@	P	'	p	_	ふ	SP	...	ク	ミ	ー	×
1		NON	!	1	A	Q	a	q	■	フ	。	ア	チ	ム	ト	四
2			"	2	B	R	b	r	■	ト	フ	イ	ツ	メ	十	年
3		ASC	#	3	C	S	c	s	■	ト	ノ	ウ	テ	モ	十	月
4			&	4	D	T	d	t	■	ー	。	ユ	ト	ヤ	▲	日
5			%	5	E	U	e	u	■	...	。	オ	サ	ユ	▲	時
6			&	6	F	V	f	v	■	ト	ク	カ	ニ	ヨ	▼	分
7			'	7	G	W	g	w	■	ト	?	キ	ヌ	ラ	▼	秒
8			(8	H	X	h	x	■	ト	イ	ク	ネ	リ	●	下
9	BT)	9	I	Y	i	y	■	ト	リ	ケ	ノ	ル	♥	市
A	LF		*	:	J	Z	j	z	■	ト	シ	コ	ハ	レ	◆	区
B		ASC	+	:	K	[k	i	■	ト	シ	サ	ヒ	ロ	♣	町
C		FS	,	<	L	V	l	v	■	ト	シ	フ	ク	●	村	
D	CR	OS	-	=	M]	m	!	■	ト	シ	ス	ヘ	ン	○	人
E			.	>	N	^	n	~	■	ト	シ	セ	ホ	*	/	■
F			/	?	O	...	o	SP	ト	ノ	ク	ソ	マ	。	\	SP

15.7 Code Page 850

128	144	160	176	192	208	224	240
8-	9-	A-	B-	C-	D-	E-	F-
Ç	È	Á	À	É	Ò	Ó	.
ù	æ	·	¸	¸	Ð	ß	±
¿	Æ	¸	¸	¸	È	Ó	=
à	ó	¸		¸	È	Ó	¸
á	ü	¸		¸	È	Ó	¸
ä	ö	¸	¸	¸	¸	¸	¸
å	û	¸	¸	¸	¸	¸	¸
ç	¸	¸	¸	¸	¸	¸	¸
è	¸	¸	¸	¸	¸	¸	¸
é	¸	¸	¸	¸	¸	¸	¸
ê	¸	¸	¸	¸	¸	¸	¸
ë	¸	¸	¸	¸	¸	¸	¸
è	¸	¸	¸	¸	¸	¸	¸
é	¸	¸	¸	¸	¸	¸	¸
ê	¸	¸	¸	¸	¸	¸	¸
ë	¸	¸	¸	¸	¸	¸	¸
è	¸	¸	¸	¸	¸	¸	¸
é	¸	¸	¸	¸	¸	¸	¸
ê	¸	¸	¸	¸	¸	¸	¸
ë	¸	¸	¸	¸	¸	¸	¸
À	×	¸	¸	¸	¸	¸	¸
Á	¸	¸	¸	¸	¸	¸	¸

15.8 Code Page 860

128	144	160	176	192	208	224	240
8-	9-	A-	B-	C-	D-	E-	F-
Ç	È	á	â	Ë	Ê	æ	ø
à	À	·	¸	É	Ë	ß	¸
é	Ê	ó	ô	Ï	Î	Ï	¸
â	â	ú	û	Ï	Ï	π	¸
ã	ä	ü	ý	Ï	Ï	Σ	¸
ä	å	ÿ	ÿ	Ï	Ï	σ	¸
Á	Û	¸	¸	Ï	Ï	μ	¸
ç	ø	¸	¸	Ï	Ï	τ	¸
è	é	é	é	Ï	Ï	φ	¸
ê	ë	ë	ë	Ï	Ï	θ	¸
é	ù	¸	¸	Ï	Ï	Γ	¸
í	í	¸	¸	Ï	Ï	δ	¸
ó	ó	¸	¸	Ï	Ï	∞	¸
	U	¸	¸	Ï	Ï	φ	¸
À	øt	¸	¸	Ï	Ï	e	¸
À	Ó	¸	¸	Ï	Ï	ü	¸

15.9 Code Page 863

128	144	160	176	192	208	224	240
8-	9-	A-	B-	C-	D-	E-	F-
Ç	É	Í	Ï	Ë	Ï	α	≠
ù	E	'	·	·	·	β	±
é	Ê	ó	·	·	·	Γ	≥
á	ò	á	·	·	·	π	≤
À	E	-	·	·	·	Σ	f
a	i	.	·	·	·	σ	J
ø	ø	³	·	·	·	π	°
ý	u	-	·	·	·	τ	»
è	à	í	·	·	·	φ	°
z	ò	·	·	·	·	θ	•
e	ó	·	·	·	·	Ω	•
-	ø	55	·	·	·	δ	√
'	£	¾	·	·	·	∞	"
~	U	¾	·	·	·	φ	z
A	ó	·	·	·	·	ε	■
§	J	·	·	·	·	∅	

15.10 Code Page 865

128	144	160	176	192	208	224	240
8-	9-	A-	B-	C-	D-	E-	F-
Ç	É	á	⋮	Ł	š	ø	≡
Ġ	œ	ı	⋮	ł	ŧ	ß	±
é	Æ	ó	⋮	ŕ	ŵ	ŕ	≥
à	ó	á		ı	š	π	≤
ü	ó	ß	-	-	Ł	Σ	/
à	ó	Ń	+	+	ŕ	ø	ſ
á	á	†	+	+	ŕ	μ	◊
ç	ó	?	+	+	+	τ	≈
é	ý	ı	+	+	+	ø	°
ø	Ö	ŕ	+	+	+	ø	•
ó	Ü	ŕ	+	+	+	ø	·
ı	ø	ſ	+	+	+	ø	√
ı	£	ſ	+	+	+	ø	°
ı	ø	ı	+	+	+	ø	²
Λ	ſ	ø	+	+	+	ø	■
Λ	ſ	ſ	+	+	+	ø	■

15.12 Code Page 866

128	144	160	176	192	208	224	240
8-	9-	A-	B-	C-	D-	E-	F-
А	Р	а	б	Л	л	р	ё
Б	С	б	в	Т	т	с	е
В	Т	в	г	Г	г	т	ё
Г	У	г	д	У	у	е	
Д	Ф	д	е	Ф	ф	л	і
Е	Х	е	ж	Х	х	г	
Ж	Ц	ж	з	Ц	ц	у	ѳ
З	Ч	з	и	Ч	ч	ѳ	
И	Ш	и	к	Ш	ш	ѳ	°
Й	Щ	й	л	Щ	щ	ѳ	°
К	Ъ	к	м	Ъ	ъ	ѳ	°
Л	Ы	л	н	Ы	ы	ѳ	°
М	Ь	м	о	Ь	ь	ѳ	№
Н	Э	н	п	Э	э	ѳ	Ω
О	Ю	о	р	Ю	ю	ѳ	■
Р	Я	р	с	Я	я	ѳ	■

15.14 Windows Code

8	9	A	B	C	D	E	F
			°	À	Ð	À	ò
	'	ı	±	Á	Ñ	Á	ñ
	'	é	²	Â	Ò	Â	ó
/	*	£	*	Ã	Ó	Ã	ô
~	~	¤	'	Ä	Ô	Ä	ö
...	•	¥	µ	Å	Ö	Å	ø
†	-	ı	¶	Æ	Ø	Æ	ö
‡	---	§	-	Ç	×	Ç	÷
^	-	-	-	È	Θ	è	θ
‰	™	©	ı	É	Ú	é	ù
Š	š	•	°	Ê	Û	ê	û
ç	˘	«	»	Ë	Ü	ë	ü
œ	œ	™	¼	İ	U	ı	u
		-	½	ı	Ÿ	ı	ÿ
		@	¾	ı	ƒ	ı	ƒ
ÿ		ı	ı	ı	B	ı	ÿ

15.15 International Character Codes Table

	Nation	23	24	40	5B	5C	5D	5E	60	7B	7C	7D	7E
0	U.S.A.	#	\$	@	{	/	}	^	'				~
1	France	#	\$	à	°	ç	§	^	'	é	ù	é	·
2	Germany	#	\$	§	À	Ö	Ü	-	'	ä	ö	ü	ß
3	U.K.	£	\$	@	{	/	}	^	'				-
4	Denmark	#	ø	@	Æ	Ø	Å	^	'	æ	ø	é	~
5	Sweden	#	ö	é	À	Ö	Å	Ö	é	ä	ö	å	ö
6	Italy	#	\$	@	°	/	é	^	ù	à	é	é)
7	Spain	PE	\$	@	i	N	¿	^	'	-	ñ		-
8	Japan	#	\$	@	{	¥	}	-	'				~
9	Norway	#	ö	é	Æ	Ø	Å	Ü	é	æ	ø	å	ö
10	Denmark 2	#	ø	é	Æ	Ø	Å	Ü	é	æ	ø	å	ö

APPENDIX 1. BLOCK DIAGRAM

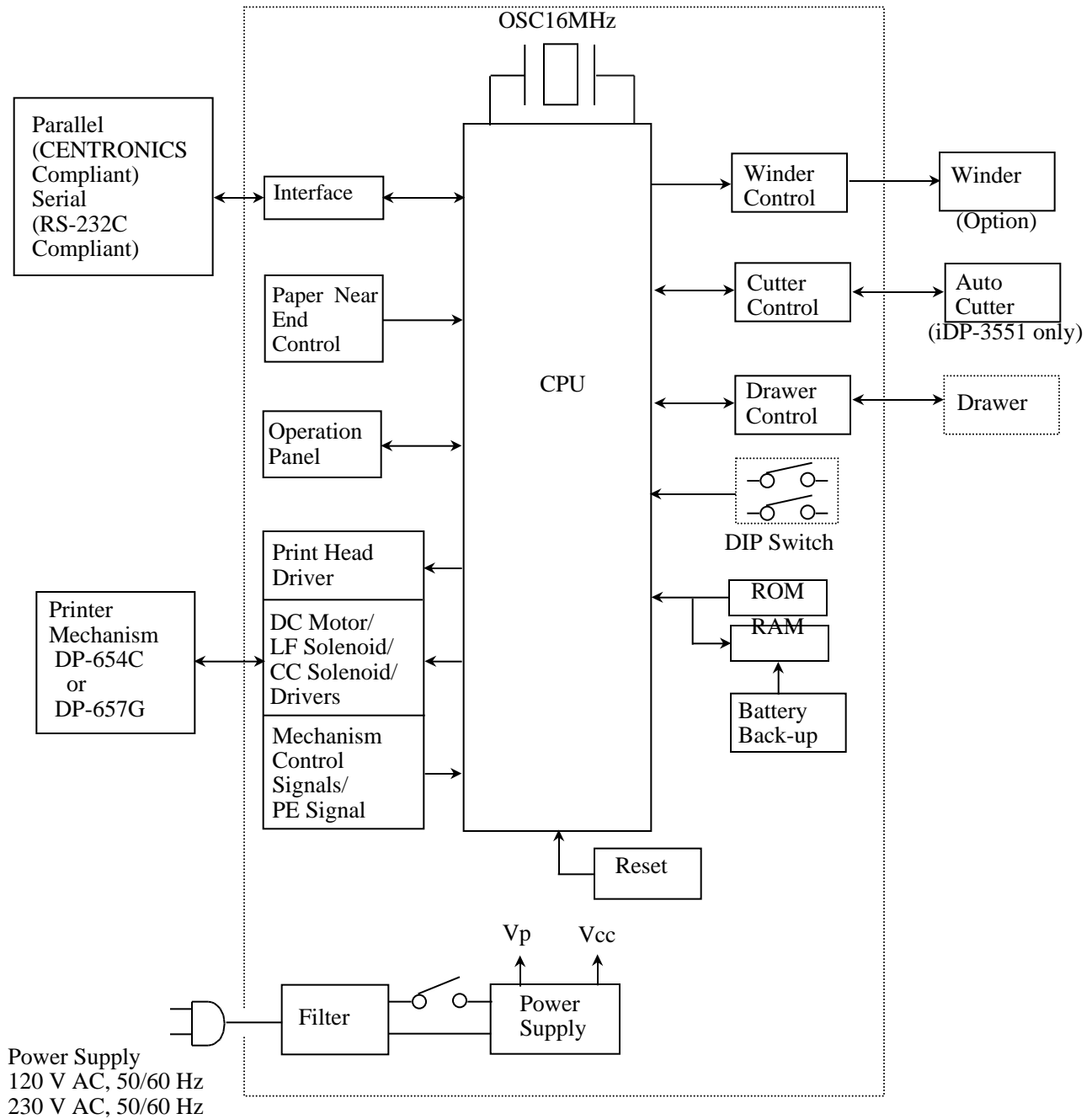

APPENDIX 2. OUTLINE DRAWING for iDP-3550

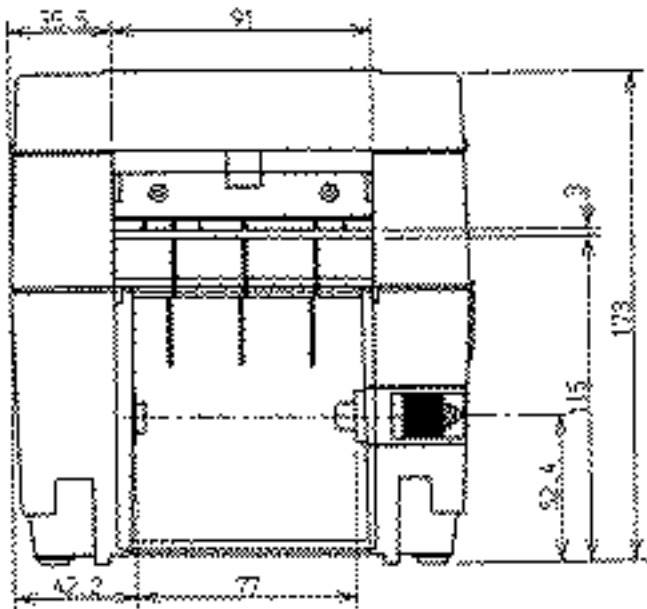
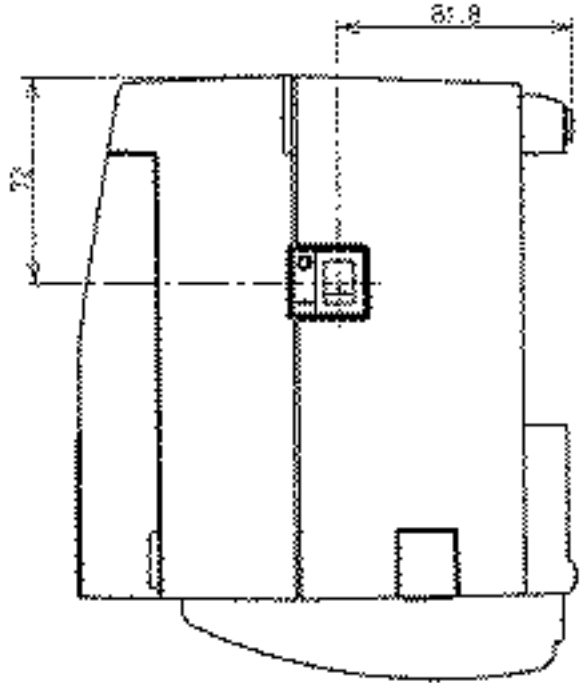
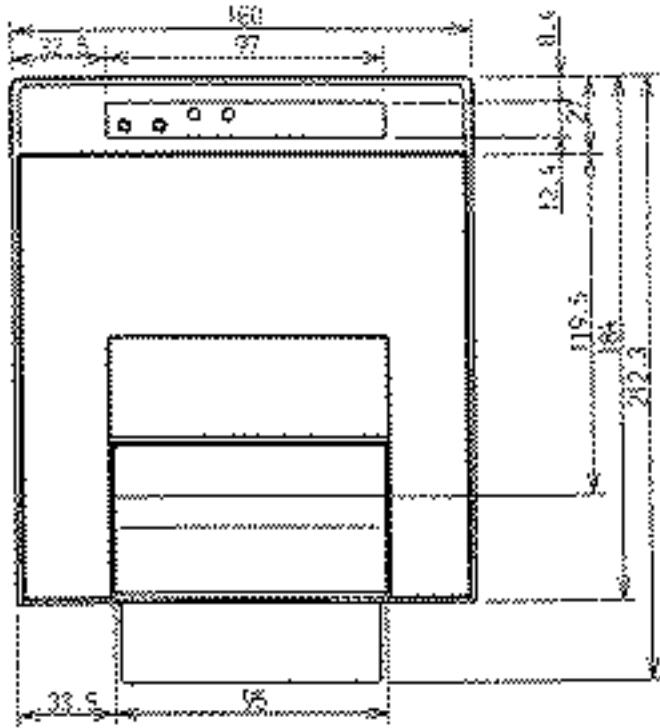

Unit: mm

<<< **German** >>>



<VORSICHT>

1. Bitte lesen Sie die Bedienungsanleitung vor dem Betrieb des Geräts aufmerksam durch und bewahren Sie die Anleitung anschließend für späteres Nachschlagen an einem sicheren Platz auf.
2. Änderungen des Inhalts dieser Anleitung bleiben ohne Vorankündigung vorbehalten.
3. Die Vervielfältigung dieser Bedienungsanleitung ohne vorherige Genehmigung verstößt, auch auszugsweise, gegen das Urheberschutzrecht.
4. Niemals versuchen, in dieser Anleitung nicht erwähnte Geräteteile eigenhändig zu warten, zerlegen oder zu reparieren.
5. Bitte beachten Sie, daß wir keinerlei Haftung für Schäden übernehmen, die auf unsächgemäße Bedienung, falsche Handhabung oder eine ungeeignete Betriebsumgebung zurückzuführen sind.
6. Zur Vermeidung von Unfällen und sonstigen Problemen ist das Gerät ausschließlich auf die in der Bedienungsanleitung beschriebene Weise zu betreiben.
7. Daten sind grundsätzlich temporär, d.h. sie können nicht permanent gesichert oder über längere Zeit gespeichert werden. Es sei deshalb darauf hingewiesen, daß wir für finanzielle Schäden oder Profitrückgänge als Folge von Datenverlust, Unfällen, Reparaturen, Tests usw. keinerlei Haftung übernehmen.
8. Bitte wenden Sie sich mit Fragen oder Hinweisen auf Fehler oder Auslassungen im Text dieser Anleitung an unsere Geschäftsstelle.
9. Beachten Sie jedoch, daß wir, ungeachtet des obigen Punkts 8, keinerlei Haftung für negative Folgeerscheinungen im Zusammenhang mit dem Betrieb dieses Geräts übernehmen.

ZU BEACHTENDE SICHERHEITSMASSREGELN

Zur Vermeidung von Gefahren gegenüber dem Bediener und anderen Personen und Sachschäden sind die folgenden Vorsichtsmaßnahmen unbedingt zu beachten.

- Der folgende Text beschreibt das Ausmaß der Gefahren und potentiellen Sachschäden, die durch eine Mißachtung der Bedienungshinweise oder durch die unsachgemäße Handhabung des Geräts entstehen können.

	WARNUNG	Die Mißachtung dieser Vorsichtsmaßregel kann zu Körperverletzungen mit möglicher Todesfolge führen.
	VORSICHT	Die Mißachtung dieser Vorsichtsmaßregel kann zu Körperverletzungen oder Sachschäden führen.
	Dieses Symbol ruft den Bediener zu erhöhter Wachsamkeit auf.	

-  Dieses Symbol weist auf wichtige Informationen, wie z.B. Bedienungsschritte oder dergleichen, hin.

WARNUNG

- Beim Betrieb des Geräts sind die nachfolgenden Vorsichtsmaßnahmen unbedingt zu beachten. Eine Mißachtung dieser Hinweise kann zu Schäden, Funktionsstörungen, Rauchentwicklung und Brandgefahr durch Überhitzen und zu elektrischen Schlägen führen.
Der fortgesetzte Betrieb des Geräts in anormalem Zustand, wie z.B. nach einer Beschädigung, kann Funktionsstörungen, Rauchentwicklung, fremde Gerüche/Geräusche und Brände verursachen. Bei anormalem Betriebszustand das Gerät sofort ausschalten und an einen Fachhändler wenden. Niemals versuchen, das Gerät eigenhändig zu reparieren, um ernsthafte Gefahren zu vermeiden.
- Das Gerät vor starken Stößen und Erschütterungen, wie z.B. Tritte, Stampfen, Schläge, Herunterfallen usw., schützen.
- Das Gerät an einem gut belüfteten Platz aufstellen, und darauf achten, die Belüftungsöffnung nicht zu blockieren.
- Bei der Aufstellung des Geräts Plätze vermeiden, an denen chemische Reaktionen auftreten, wie z.B. in einem Labor, sowie Plätze mit salz- oder gashaltiger Umgebungsluft.
- Netz- und Datenkabel niemals am Kabel haltend anschließen oder abziehen. Bei Betrieb, Verrücken oder Tragen des Geräts darauf achten, daß die Kabel keiner Gewalteinwirkung ausgesetzt sind.
- Darauf achten, daß keine Fremdkörper, wie z.B. Nadeln oder Büroklammern, in das Gerät gelangen.
- Darauf achten, keine Flüssigkeiten auf dem Gerät zu vergießen oder chemische Substanzen enthaltende Sprays darüber zu versprühen. Bei versehentlichem Naßwerden das Gerät sofort ausschalten, das Stromanschlußkabel abziehen, das Netzkabel von der Steckdose trennen usw. und an einen Fachhändler wenden.
- Das Gerät niemals eigenhändig zerlegen oder modifizieren. Eine Mißachtung dieser Vorsichtsmaßregel kann zu Bränden und elektrischen Schlägen führen.
- Sollte unbeabsichtigt Wasser in das Gerät eindringen, sofort den Netzstecker abziehen und an einen Fachhändler wenden. Der fortgesetzte Betrieb in diesem Zustand kann zu Bränden und elektrischen Schlägen führen.
- Das Gerät ausschließlich mit der vorgeschriebenen Netzspannung betreiben. Eine Mißachtung dieser Vorsichtsmaßregel kann Brände, elektrische Schläge und Funktionsstörungen verursachen.
- Beschädigen Sie das Netzkabel nicht, indem Sie es brechen, verbiegen, verändern, extrem verdrehen, ziehen oder bündeln. Vermeiden Sie es auch, schwere Gegenstände auf das Netzkabel zu stellen oder es zu erhitzen. Dadurch kann das Netzkabel beschädigt werden was dann u.U. zu Bränden, elektrischen Schlägen oder Fehlfunktionen führt. Sollte das Netzkabel beschädigt worden sein, wenden Sie sich an Ihren Fachhändler.
- Stecken bzw. entfernen Sie das Netzkabel nicht mit nassen Händen in die bzw. von der Steckdose. Es besteht sonst die Gefahr von elektrischen Schlägen.
- Das Netzteil niemals mit nassen Händen anschließen oder trennen. Hierdurch können Brände, elektrische Schläge und sonstige Probleme entstehen.
- Verpackungsbeutel sind vorschriftsgemäß zu entsorgen oder ansonsten von Kindern fernzuhalten. Kleinkinder können durch Überstreifen eines Plastikbeutels ersticken.



VORSICHTSMASSREGELN FÜR DIE AUFSTELLUNG

- Das Gerät nicht an Plätzen abstellen oder betreiben, an denen es Feuer, Feuchtigkeit oder direkter Sonnenbestrahlung ausgesetzt ist. Ebenso sind Plätze in der Nähe von Heizkörpern und sonstigen Wärmequellen zu vermeiden, an denen Umgebungstemperatur und Luftfeuchtigkeit nicht den vorgeschriebenen Betriebsbedingungen entsprechen, sowie Plätze, an denen das Gerät Öl, Metallspänen oder Staub ausgesetzt ist. Andernfalls können Funktionsstörungen sowie Rauch- und Brandentwicklung die Folge sein.
- Bei der Aufstellung des Geräts Plätze vermeiden, an denen chemische Reaktionen auftreten, wie z.B. in einem Labor, sowie Plätze mit salz- oder gashaltiger Umgebungsluft. Hierbei besteht die Gefahr von Bränden und elektrischen Schlägen.
- Keine schweren Gegenstände auf den Drucker stellen, um mögliche Probleme zu vermeiden.
- Das Gerät nicht in der Nähe eines Radios oder Fernsehers verwenden und nicht zusammen mit einem Radio oder Fernseher an die gleiche Steckdose anschließen. Hierdurch können Empfangsstörungen auftreten.
- Das Gerät ausschließlich mit der vorgeschriebenen Netzspannung und -frequenz betreiben. Eine Mißachtung dieser Vorsichtsmaßregel kann Brände, elektrische Schläge und Funktionsstörungen verursachen.
- Vergewissern, daß die für den Anschluß des Netzkabels verwendete Steckdose über eine ausreichende Kapazität verfügt.
- Darauf achten, eine einzelne Steckdose nicht durch den Anschluß des Netzkabels zu überlasten. Andernfalls können Brände und Stromausfälle die Folge sein. Darüber hinaus nicht fest auf das Netzkabel treten oder schwere Gegenstände darauf abstellen.
- Erdungskabel niemals an ein Gasrohr anschließen, da hierbei Explosionsgefahr besteht. Vor dem Anschließen oder Trennen eines Erdungskabels unbedingt zuerst den Netzstecker aus der Steckdose ziehen.
- Beim Anschließen oder Trennen der Kabel zuerst die Netzversorgung ausschalten, einschließlich der angeschlossenen Seite, und dann an Stecker und Steckdose haltend anschließen bzw. trennen. Bei einem Transport des Geräts darauf achten, daß das Kabel keinem Zug ausgesetzt ist.
- Steckerkabel sind fest anzuschließen. Durch Anschluß mit umgekehrter Polarität können Innenbauteile oder Paßflächen beschädigt werden.
- Für Datensignalleitungen abgeschirmte Kabel oder verzwirbelte Doppeladerkabel verwenden, um Rauschstörungen möglichst gering zu halten. Der Anschluß an ein Rauschstörungen erzeugendes Gerät ist zu vermeiden.
- Falls ein Geldschubladen-Ausschubmechanismusstecker vorhanden ist, sollten keine anderen Vorrichtungen, die nicht den vorgeschriebenen Solenoidspezifikationen entsprechen, angeschlossen werden. Eine Mißachtung dieser Vorsichtsmaßregel kann zu Fehlfunktionen führen.
- Das Gerät an einem Platz in der Nähe einer Steckdose betreiben, wo sich der Netzstecker zum Unterbrechen der Stromversorgung jederzeit schnell und mühelos abziehen läßt.
- Das Netzkabel aus der Steckdose ziehen, wenn das Gerät längere Zeit lang nicht benutzt werden soll.
- Vor einem Transport die Papierrolle aus dem Gerät herausnehmen.
- Das Gerät auf einer ebenen, stabilen Tischplatte an einem gut belüfteten Platz und frei von Erschütterungen aufstellen. (Darauf achten, die Belüftungsöffnung nicht zu blockieren.)



VORSICHTSMASSREGELN FÜR DIE HANDHABUNG

Zur Vermeidung von Problemen sind bei der Handhabung des Geräts die folgenden Vorsichtsmaßnahmen zu beachten.

- Für die Stromversorgung ausschließlich das vorgeschriebene Netzteil verwenden.
- Den Druckbetrieb nicht ohne eingelegtes Papier oder ohne Farbband starten, da hierdurch der Druckkopf beschädigt werden kann.
- Darauf achten, daß keine Fremdkörper, wie z.B. Nadeln, Büroklammern oder Schrauben, in das Gehäuse gelangen.
- Darauf achten, keine Flüssigkeiten auf dem Gerät zu vergießen oder chemische Substanzen enthaltende Sprays darüber zu versprühen.
- Das Gerät vor starken Stößen und Erschütterungen bewahren und nicht fallen lassen.
- Niemals mit spitzen Objekten, wie z.B. einem Kugelschreiber, auf das Bedienfeld drücken.
- Papierblätter niemals zum fortlaufenden Drucken mit Klebestreifen zusammenkleben.
- Ein bereits eingezogenes Blatt niemals gewaltsam herausziehen. Beim Öffnen/Schließen der Druckerabdeckung darauf achten, daß sich das Papier nicht verfängt.

Zur Vermeidung von Verletzungen und Schäden

- Den druckenden Abschnitt des Druckkopfes nicht berühren.
- Bei Einschalten keine beweglichen Teile, wie z.B. Schneidklinge und Zahnrad im Druckergehäuse, oder elektrische Teile berühren.
- Darauf achten, körperliche Verletzungen und die Beschädigung anderer Objekte durch scharfe Kanten zu vermeiden.
- Bei Auftreten jeglicher Störungen während des Betriebs den Drucker sofort ausschalten, und das Netzkabel aus der Steckdose ziehen.
- Die Beseitigung von Betriebsstörungen ist qualifiziertem Fachpersonal zu überlassen. Niemals versuchen, das Gerät eigenhändig zu zerlegen.
- Beim Öffnen/Schließen der Druckerabdeckung darauf achten, nicht die Hand oder Finger am Drucker einzuklemmen.

① TÄGLICHE WARTUNG

- Vor der Wartung zuerst den Drucker ausschalten.
- Schmutz und Staub mit einem trockenen, weichen Tuch vom Druckergehäuse abwischen. Bei starker Verschmutzung einen Lappen in Wasser anfeuchten, auswringen und damit abwischen. Hierzu niemals flüchtige organische Lösungsmittel, wie z.B. Alkohol, Terpentin, Trichlorethan, Benzol, Keton oder chemische Staubentfernungsmittel, verwenden.
- Papierstaub mit einer weichen Bürste vom Gehäuse entfernen.

4. BETRIEB

4.1 Druckerabdeckung Aufsetzen, Entfernen

1. Benutzen Sie beide Hände, um die Aussparungen an jeder Seite der Druckerabdeckung anzufassen und sie anzuheben. Heben Sie die Druckerabdeckung in Pfeilrichtung an, um sie zu entfernen.
2. Wollen Sie die Druckerabdeckung wieder aufsetzen, setzen Sie die Halterung der Druckerabdeckung vorne in den Drucker ein und senken Sie die Abdeckung auf den Drucker ab.

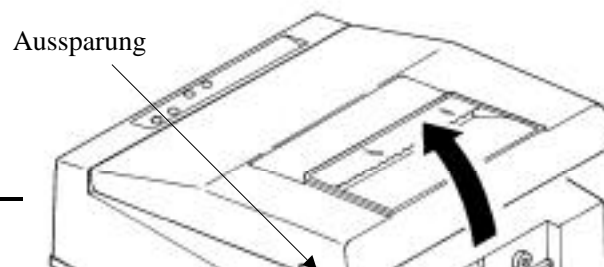

4.2 Anschluß des Schnittstellenkabels

1. Den Drucker ausschalten. (Einschließlich Kontaktseite)
2. Den Stecker korrekt ausrichten und an die Schnittstellenbuchse anschließen.
3. Den Kabelstecker an der Buchse befestigen.
 Serienschnittstelle : Die Steckerschrauben eindrehen.
 Parallelschnittstelle : Die Klemmen andrücken.
4. Das Schnittstellenkabel an den Computer anschließen.

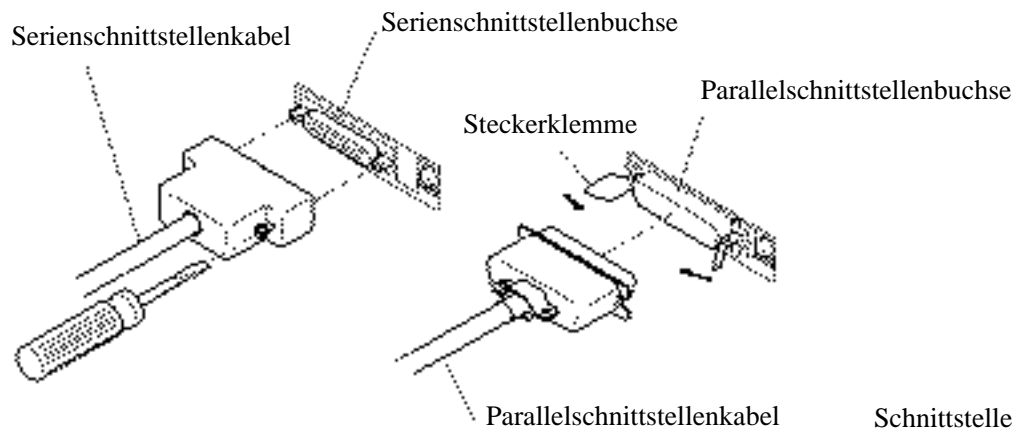

4.3 Anschluß des Schubladenausschubsteckers

1. Das Gerät ausschalten.
2. Prüfen Sie die Ober- und Unterseite des Anschlusses für den Schubladenausschubstecker und schließen Sie ihn an den Anschluß des Schubladenausschubsteckers am unteren Teil des Druckers an.
3. Schrauben Sie das Erdungskabel der Schublade an den Erdungsanschluß an, den Sie am unteren Teil des Druckers sehen.

 **VORSICHT:** Nur den vorgeschriebenen Lade-(Magneten) an den Laden-Auszugstecker anschließen.

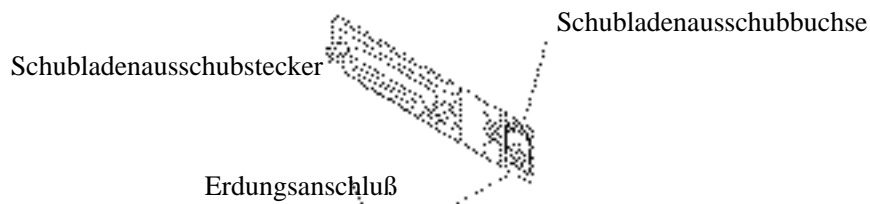

4.5 Öffnen/Schließen des automatischen Schneidemechanismus

1. Halten Sie den automatischen Schneidemechanismus fest, während Sie den Feststellhebel drücken. Drehen Sie den Schneidemechanismus in die angezeigte Richtung, um ihn zu öffnen.
2. Wenn Sie den automatischen Schneidemechanismus schließen, prüfen Sie, ob der Feststellhebel sicher eingerastet ist.

 **VORSICHT:** Den automatischen Schneidemechanismus behutsam schließen, um Stöße zu vermeiden.

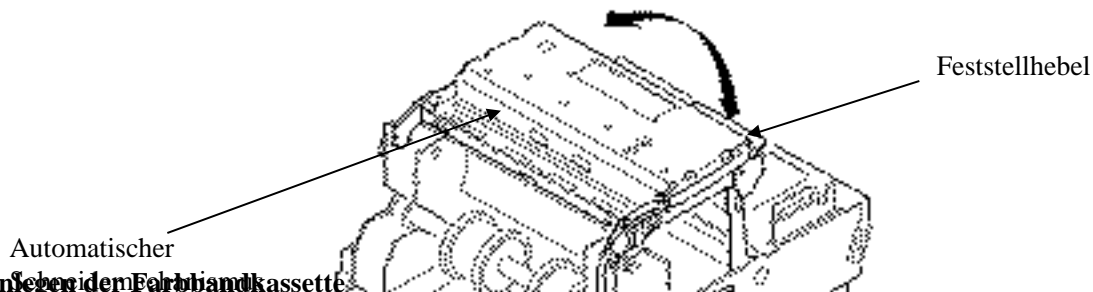

4.5 Einlegen des Farbbandkassette

1. Stellen Sie sicher, daß der Netzschalter des Druckers ausgeschaltet ist.
2. Entfernen Sie die Druckerabdeckung.
3. Öffnen Sie den automatischen Schneidemechanismus. (iDP-3551)
4. Sollte sich eine Schlaufe des Farbbandes gebildet haben, drehen Sie den Knopf auf der Farbbandkassette in Pfeilrichtung, um das Farbband zu straffen, bevor Sie es in den Drucker einsetzen.
5. Legen Sie das Farbband zwischen Druckkopf und Farbbandführung ein. Drücken Sie die Halteklemmen in die Halter des Druckers. Sie werden ein Klicken hören.
6. Drehen Sie den Knopf der Farbbandkassette in die durch den Pfeil angezeigte Richtung, um eventuelle Schlaufen des Bandes zu beseitigen.
7. Um die Farbbandkassette zu entfernen, heben Sie sie an, während Sie gleichzeitig die Halteklemmen nach innen drücken. Die Halteklemmen befinden sich auf beiden Seiten.
8. Schließen Sie den automatischen Schneidemechanismus. (iDP-3551)
9. Setzen Sie die Druckerabdeckung wieder auf.

 **VORSICHT:** •Den automatischen Schneidemechanismus vorsichtig schließen.

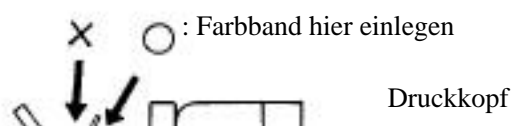

4.6 Einlegen des Papiers

1. Das Ende der Papierrolle im rechten Winkel abschneiden.



- VORSICHT:**
- Ausschließlich die vorgeschriebene Papiersorte verwenden.
 - Die Verwendung anderer Papiersorten kann zu verminderter Druckqualität, verkürzter Betriebslebensdauer des Druckers u. dergl. führen.
 - Das in den Drucker einzuführende Papierende darf nicht geknickt oder eingerissen sein.
2. Prüfen Sie die Wickelrichtung der Papierrolle. (Siehe Abbildung auf der nächsten Seite.)
 3. Öffnen Sie den Papierhalter und legen Sie die Papierrolle ein, so daß sie von dem Papierhalter sicher

Gut



Schlecht

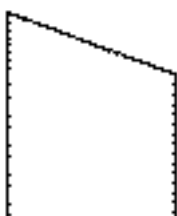

Schlecht

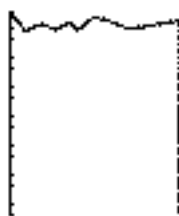

Schlecht



geführt wird.

4. Den Drucker einschalten.
5. Das Papierrollenende gerade in die Papiereinzuöffnung (markiert durch einen Pfeil) einführen.
6. Das Papier wird automatisch eingezogen und tritt am Papierauslauf des Druckers aus (Papierauslauf des automatischen Schneidemechanismus für den iDP-3551).
Sie können überschüssiges Papier an der Papierabreißkante abreißen.



- VORSICHT:**
- Lockeres Papier straffwickeln.
 - Das Papier während des Druckens nicht festhalten, da hierdurch Papierstaus entstehen können.
 - Den automatischen Schneidemechanismus vorsichtig schließen, um Stöße zu vermeiden.

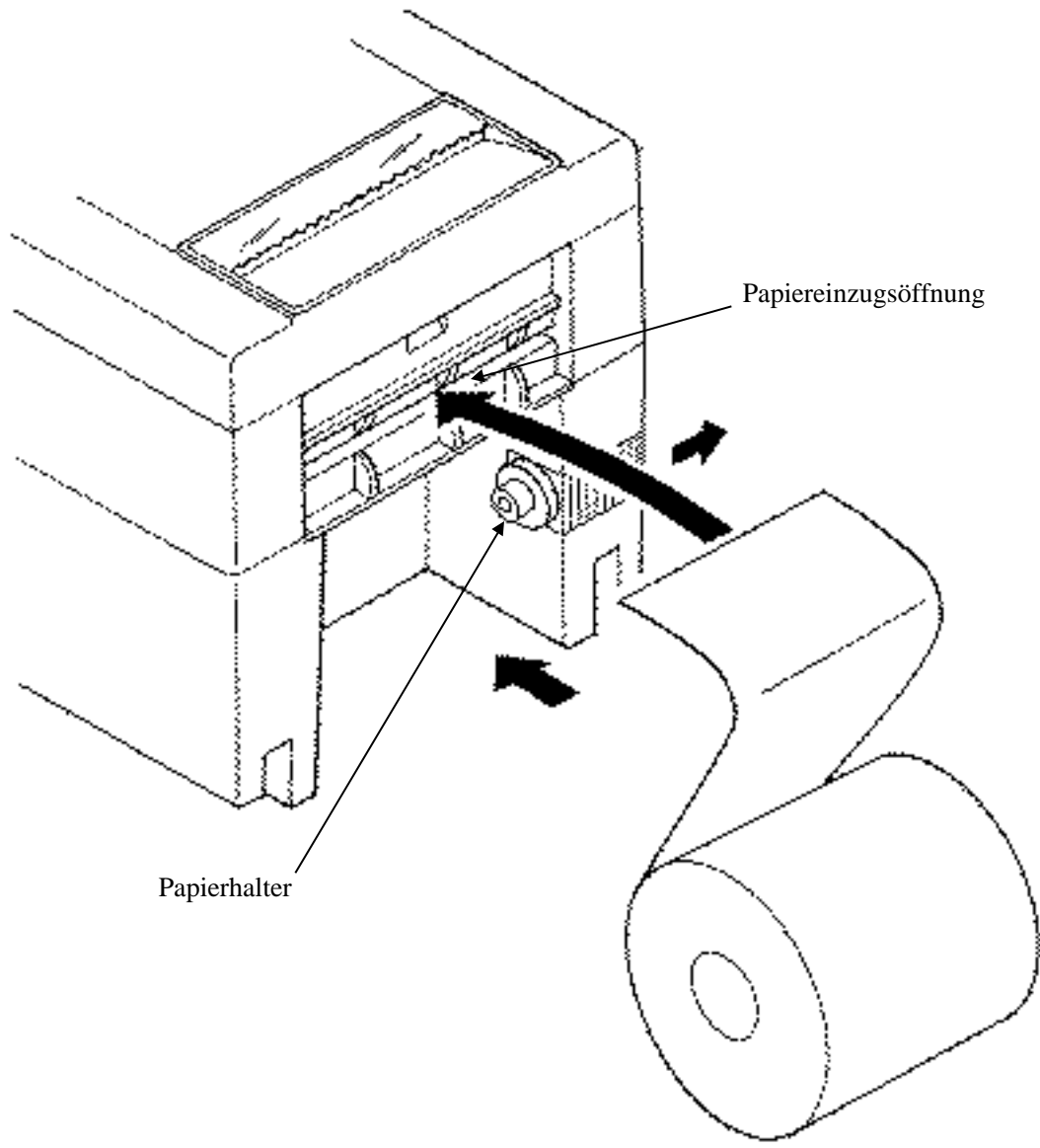

Papiereinzugsöffnung

Papierhalter

4.7 Hintere Abdeckung des Druckers aufsetzen

Setzen Sie die Klammern der hinteren Druckerabdeckung in die rechteckigen Löcher an der Rückseite des Druckers ein und schließen Sie die hintere Abdeckung in die durch den Pfeil angezeigte Richtung.

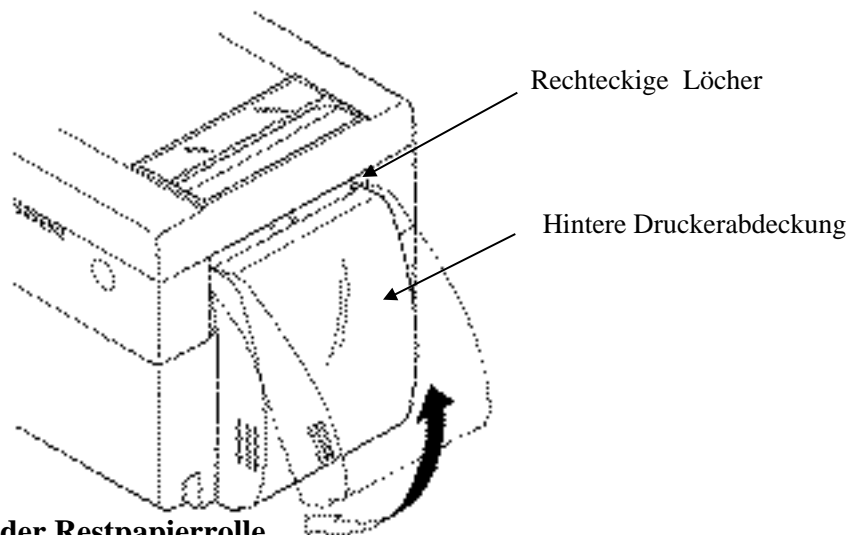

4.8 Herausnehmen der Restpapierrolle

1. Die Druckerabdeckung öffnen.
2. Den automatischen Schneidemechanismus (iDP-3551) öffnen.
3. Entfernen Sie das Papier, indem Sie es in die Richtung ziehen, in die es normalerweise bewegt wird.
4. Den automatischen Schneidemechanismus (iDP-3551) schließen.
5. Setzen Sie die Druckerabdeckung wieder auf.

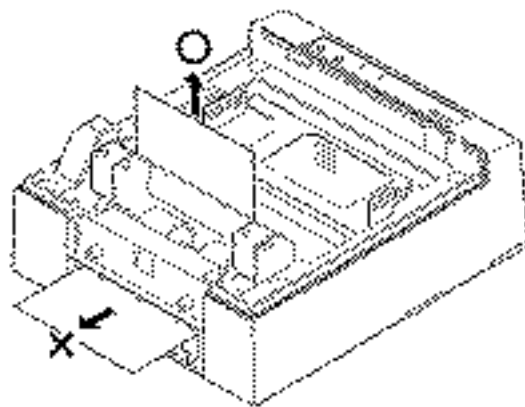

VORSICHT: • Wenn Sie das Papier entfernen, ziehen Sie es nicht aus der Papiereinzugsöffnung. (Entfernen Sie das Papier nicht in der entgegengesetzten Richtung.)

- Den automatischen Schneidemechanismus behutsam schließen, um Stöße zu vermeiden.

4.9 Beseitigung von Papierstaus

1. Die Druckerabdeckung öffnen.
2. Das Papier an der Papiereinzugsöffnung abtrennen.
3. Den Papierfreigabehebel in Pfeilrichtung stellen. Die Papiervorschubwalze gibt hierdurch das Papier frei, so daß der Papierstau beseitigt werden kann.
4. Jegliches im Papierweg aufgestaute Papier beseitigen.



- VORSICHT:**
- Wenn Sie das Papier entfernen, ziehen Sie es nicht aus der Papiereinzugsöffnung. (Entfernen Sie das Papier nicht in der entgegengesetzten Richtung.)
 - Den automatischen Schneidemechanismus behutsam schließen, um Stöße zu vermeiden.

4.10 Initialisierung des Schneidemechanismus

1. Entfernen Sie die Druckerabdeckung.
2. Die LF-Taste drücken. Hierdurch wird der automatische Schneidemechanismus initialisiert, die Schneidklinge zurückgezogen und der Alarm gelöscht.
3. Bei Auftreten eines Papierstaus das gestaute Papier vollständig entfernen. Siehe hierzu 4.9 "Beseitigung von Papierstaus".
4. Falls sich der Alarm hierdurch nicht löschen läßt, die Netzversorgung ausschalten und den automatischen Schneidemechanismus öffnen.
5. Durch ein kleines Loch an der Rückseite des automatischen Schneidemechanismus läßt sich ein Notfallknopf erkennen. Diesen Knopf mit einer Pinzette, einem Schraubendreher o. dergl. in die durch den Pfeil angezeigte Richtung drehen, um die Schneidklinge zurückzuziehen. Gestautes Papier oder Papierreste vollständig entfernen, falls vorhanden.
6. Setzen Sie die Druckerabdeckung wieder auf.

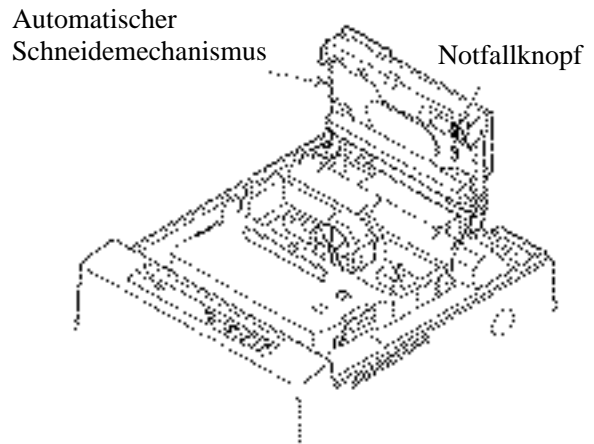

- VORSICHT:**
- Beim Herausziehen des Papiers (in Vorwärts- oder Rückwärtsrichtung) unbedingt den Papierfreigabehebel betätigen.
 - Den automatischen Schneidemechanismus behutsam schließen, um Stöße zu vermeiden.

4.11 Bedienfeld und Fehleranzeigen

1. Netzanzeigelämpchen (POWER) (grün)
Dieses Lämpchen leuchtet bei eingeschalteter Netzversorgung.
2. Fehlerlämpchen (ERROR) (grün)
Dieses Lämpchen leuchtet oder blinkt zur Anzeige eines Fehlers.

Fehleranzeige	ERROR-Lämpchen	Signalgeber	Rückstellmethode
Mechanischer Fehler	Rasches Blinken	Etwa 1 Sekunde anhaltender Signalton	Den Netzschalter rückstellen.
Papierende	Blinkt	Drei kurze Signaltöne, in Abstand von 0,6 Sekunden wiederholt werden	Eine neue Papierrolle einlegen.
Papierrolle fast leer	Blinkt (in Sekundenabständen)	Drei kurze Signaltöne, in Abstand von 0,6 Sekunden wiederholt werden	Eine neue Papierrolle einlegen.
Motorsperre des Schneidemechanismus	Rasches Blinken (zweimal pro Sekunde)	Etwa 1 Sekunde langer Signalton	Den Papierstau beseitigen.

(nur iDP-3421/23)			
-------------------	--	--	--

Mechanischer Fehler : Wenn der Druckmechanismus aufgrund eines Papierstaus o. dergl. höher als normal belastet wird, erklingt ein Signalton, und das SEL/ERROR-Lämpchen blinkt, um den Druckmechanismus zu stoppen.

Papierende : Sollte das Ende der Papierrolle erreicht sein, wird das durch den Papierrestsensor erkannt, der sich in der Nähe des Druckkopfes befindet. Es wird ein Signalton erzeugt und das Lämpchen SEL/ERROR blinkt, um den Druckmechanismus zu stoppen. Wird Papier in den Papierpfad eingelegt, wird die Papierrolle geladen. (Siehe 4.6 Einlegen des Papiers)

Papiervorrat fast leer : Bei aufgebrauchtem Papiervorrat wird der Papierrestsensor zum Einschalten des Signalgebers und des SEL/ERROR-Lämpchens aktiviert. Selbst nach Erkennen des zuende gehenden Papiervorrats kann die gewünschte Anzahl von Zeilen durch Eingeben eines Befehls gedruckt werden. (Siehe die Beschreibung des Befehls zum Einstellen der Druckzeilenanzahl nach der Erkennung des zuende gehenden Papiervorrats.)

Schneidemechanismus-Motorsperre :
(nur iDP-3551)

Wenn der Schneidepositionssensor in der Papierschneideeinheit bei laufendem Schneidemotor länger als 1 Sekunde ein- oder ausgeschaltet ist, wird die Schneide- und Druckfunktion durch Sperren des Motors ausgeschaltet.

Pufferdaten löschen : Ist der Drucker eingeschaltet, werden entsprechend der Funktion des Schalters SEL, die Pufferdaten im Eingangsspeicher gelöscht, wie Sie das im Flußdiagramm auf der nächsten Seite sehen.

Um die Pufferdaten im Eingangsspeicher zu löschen, schalten Sie den Drucker ein, während Sie gleichzeitig den Schalter SEL drücken. Es wird die folgende Meldung gedruckt.

“Clear Data in Buffer”

“Cleared Data in Buffer”

Um die Pufferdaten im Eingangsspeicher zu drucken, schalten Sie einfach den Drucker ein. Es wird die folgende Meldung gedruckt und die Daten des Eingangsspeichers werden gedruckt.

“Power Down(Data in Buffer)”

Testdruck : Um sich einen Testdruck drucken zu lassen, schalten Sie den Drucker ein, während Sie gleichzeitig den Schalter LF drücken.

Dumpmodus: : Um in den Dumpmodus zu schalten, schalten Sie den Drucker ein, während Sie gleichzeitig den Schalter LF und SEL drücken. Es wird die folgende Meldung gedruckt.

“=== Hexadecimal Dump ===”

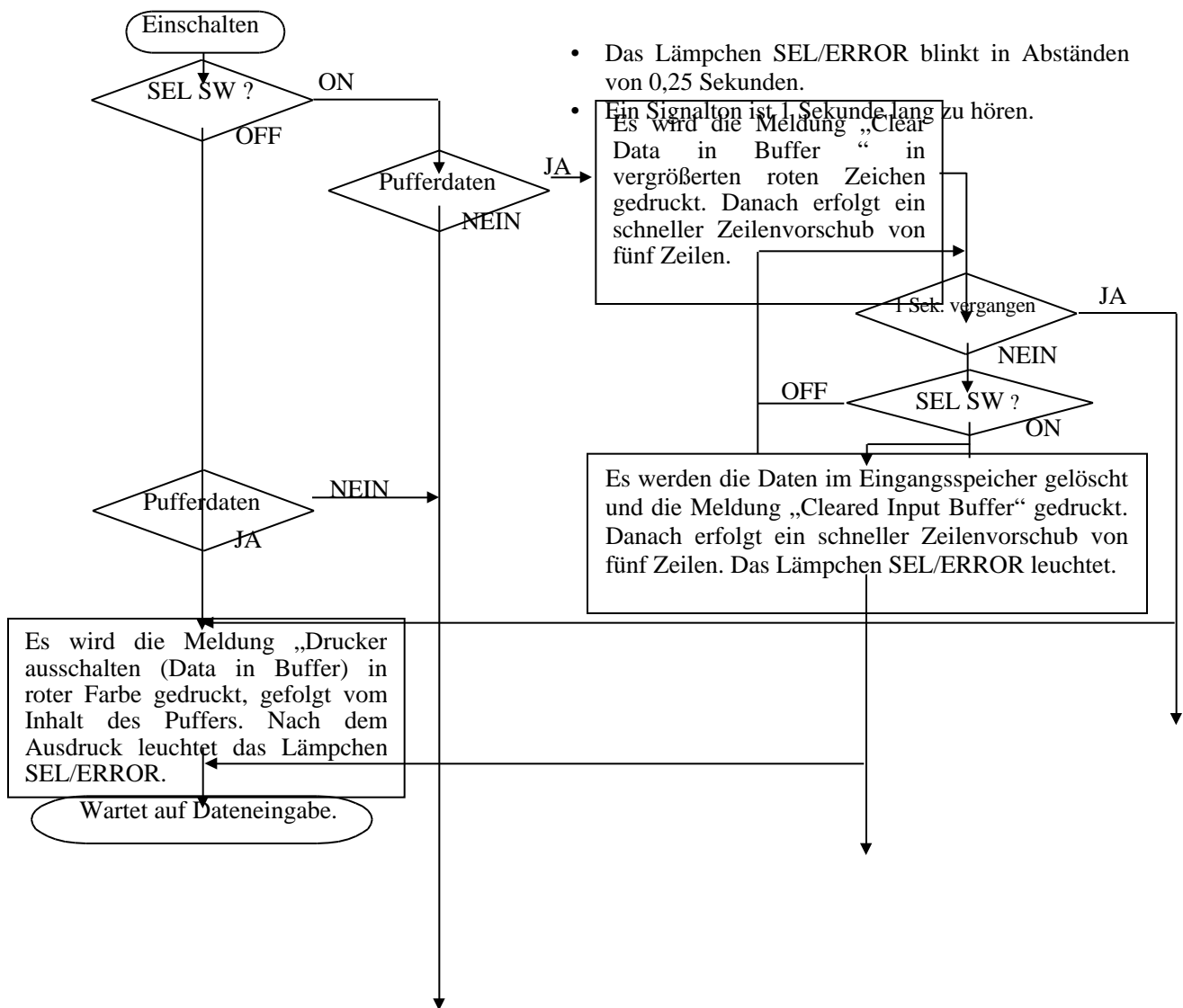

5. DIP-SCHALTER-EINSTELLUNG

5.1 Lage der DIP-Schalter

1. Das Gerät ausschalten.
2. Entfernen Sie die Druckerabdeckung.
3. Der DIP-Schalter befindet sich an der Stelle, wie in der Abbildung unten gezeigt. (Nur DSW2 steht für die serielle Schnittstelle zur Verfügung.)

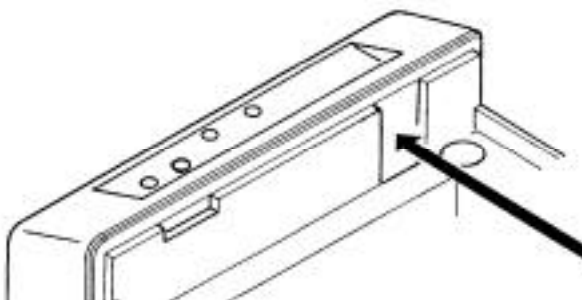

5.2 DIP-Schalter-Einstellungen

1) DIP-Schalter 1

No.	Funktion	ON	OFF	Bei Auslieferung ab Werk
DSW1-1	Automatische Schneideinheit	Ja	Nein	ON *1
DSW1-2	Internationale Zeichen	Siehe Tabelle unten		ON *2
DSW1-3				ON *2
DSW1-4				ON *2
DSW1-5	CBM command	iDP-3530 system	iDP-3540 system	OFF*4
DSW1-6	CR-Modus	Siehe Tabelle unten		OFF
DSW1-7	Mechanism Type	Graphic	Character	OFF
DSW1-8	Puffergröße	6K Byte	256 Byte	ON
DSW1-9	Betriebsmodus	Siehe Tabelle unten		OFF *3
DSW1-10				OFF *3

*1, *3: Je nach Typ.

*2: Je nach Bestimmungsort.

*4: Nur aktiv, wenn der CBM-Modus mit Hilfe der Schalter DSW1-9 und -10 eingeschaltet ist. Weitere Einzelheiten siehe 13.1 „CBM-Modus“.

Internationale Zeichenwahl

Land \ No.	DSW1-2	DSW1-3	DSW1-4
U.S.A.	ON	ON	ON
Frankreich	OFF	ON	ON
Deutschland	ON	OFF	ON
Großbritannien	OFF	OFF	ON
Dänemark	ON	ON	OFF
Schweden	OFF	ON	OFF
Italien	ON	OFF	OFF
Japan	OFF	OFF	OFF

Zeichencode-Wahl

ESC/POS-Modus	CBM-Modus	Star-Modus
Code 437	CBM (international)	Star (international)
Code 850	Code 850	Code 850
Katakana	CBM (japanisch)	Star (japanisch)

Siehe internationale Zeichencode-Tabelle und Schriftzeichen-Tabelle

CR-Modus(DSW1-6)

Modus	OFF	ON
CBM	CR+LF	CR
STAR	CR+LF	Ignoriert
ESC/POS	CR+LF	CR

Betriebsmodus DSW1-9 DSW1-10

	DSW1-9	DSW1-10
CBM	OFF	OFF
ESC/POS	ON	OFF
STAR	OFF	ON
STAR Auto-Schneidfunktion	ON	ON

2) DIP-Schalter 2

No.	Funktion	ON	OFF	Werksseitige Einstellung
DSW2-1	Bitlänge	8 Bit	7 Bit	ON
DSW2-2	Parität	Nein	Ja	ON
DSW2-3	Ungerade/Gerade	Ungerade	Gerade	ON
DSW2-4	Kommunikationsmodus	DTR/DSR	XON/XOFF	ON
DSW2-5	Baudrate	Siehe Tabelle unten		ON
DSW2-6				ON
DSW2-7				OFF
DSW2-8	Nicht verwendet			OFF

Baudrate

Baudrate	DSW2-5	DSW2-6	DSW2-7
150	OFF	OFF	OFF
300	OFF	OFF	ON
600	OFF	ON	OFF
1200	OFF	ON	ON
2400	ON	OFF	OFF
4800	ON	OFF	ON
9600	ON	ON	OFF
19200	ON	ON	ON

Der DIP-Schalter 2 wird nur für die serielle Schnittstelle verwendet.

6. EINSTELLUNG DER VORWAHL-JUMPERSTECKER

6.1 Lage der Vorwahl-Jumperstecker

1. Betriebsstrom ausschalten.
2. Die Vorwahl-Jumperstecker werden ab Werk, vor dem Versand eingestellt. Wollen Sie diese Einstellungen ändern, entfernen Sie die Steuerplatine und ändern Sie die Einstellungen entsprechend den Anweisungen des Service-Handbuches.

Die Lage der Vorwahl-Jumperstecker sehen Sie in der folgenden Abbildung.

Serielle Schnittstelle

Parallele Schnittstelle

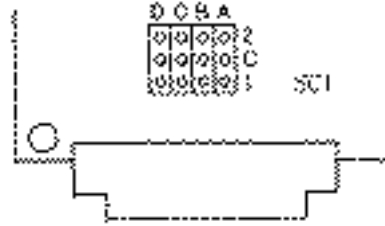
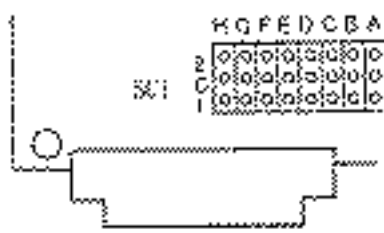

6.2

Lage \ Modus	CBM	STAR	ESC/POS
SCA	1-C *	2-C	2-C
SCB	1-C *	1-C *	2-C
SCC	1-C	2-C	*
SCD	1-C	2-C	*
SCE	1-C *	2-C	1-C *
SCF	1-C *	2-C	1-C *
SCG	1-C *	2-C	1-C *
SCH	1-C	2-C *	2-C *

* = Offen

1-C* = 1-C oder offen

2-C* = 2-C oder offen

Parallel

Lage \ Modus	CBM	STAR	ESC/POS
SCA	1-C *	1-C	2-C *
SCB	1-C	1-C	2-C
SCC	1-C *	1-C *	2-C
SCD	1-C	1-C	2-C *

* = Offen

1-C* = 1-C oder offen

2-C* = 2-C oder offen

Einstellung der Vorwahl-Jumperstecker

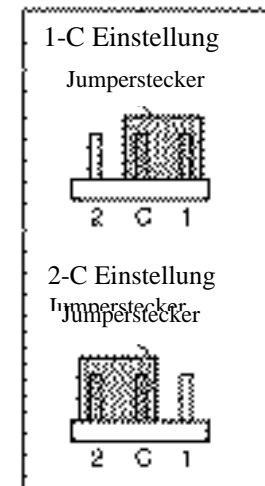

7. METHODE FÜR MODUSEINSTELLUNG

Dieser Drucker hat die Modi CBM, STAR und ESC/POS. Jeder gewünschte Modus kann gewählt und nach Bedarf eingestellt werden.

(1) Einstellmethode

- Siehe 5. DIP-SCHALTER-EINSTELLUNG
- Unter bezug auf die Einstellungen der DIP-Schalter-Segmente 1-9 und 1-10 und die der Vorwahl-Jumperstecker jeden Modus einstellen.

12. WARTUNG UND DIENST

Bitte wenden Sie sich an die folgenden Stellen für weitergehende Informationen.

Nordamerika

CBM America Corporation
Service Center
365 Van Ness Way
Suite 510
Torrance, CA 90501, USA

TEL +1-310-781-1460

FAX +1-310-781-9157

Andere Gebiete

Japan CBM Corporation
Information Systems Division
CBM Bldg., 5-68-10, Nakano
Nakano-ku, Tokyo 164-0001
Japan

TEL +81-3-5345-7540

FAX +81-3-5345-7541